

M. ENGEL.
Bee Hive.

No. 1,555.

Patented April 15, 1840.

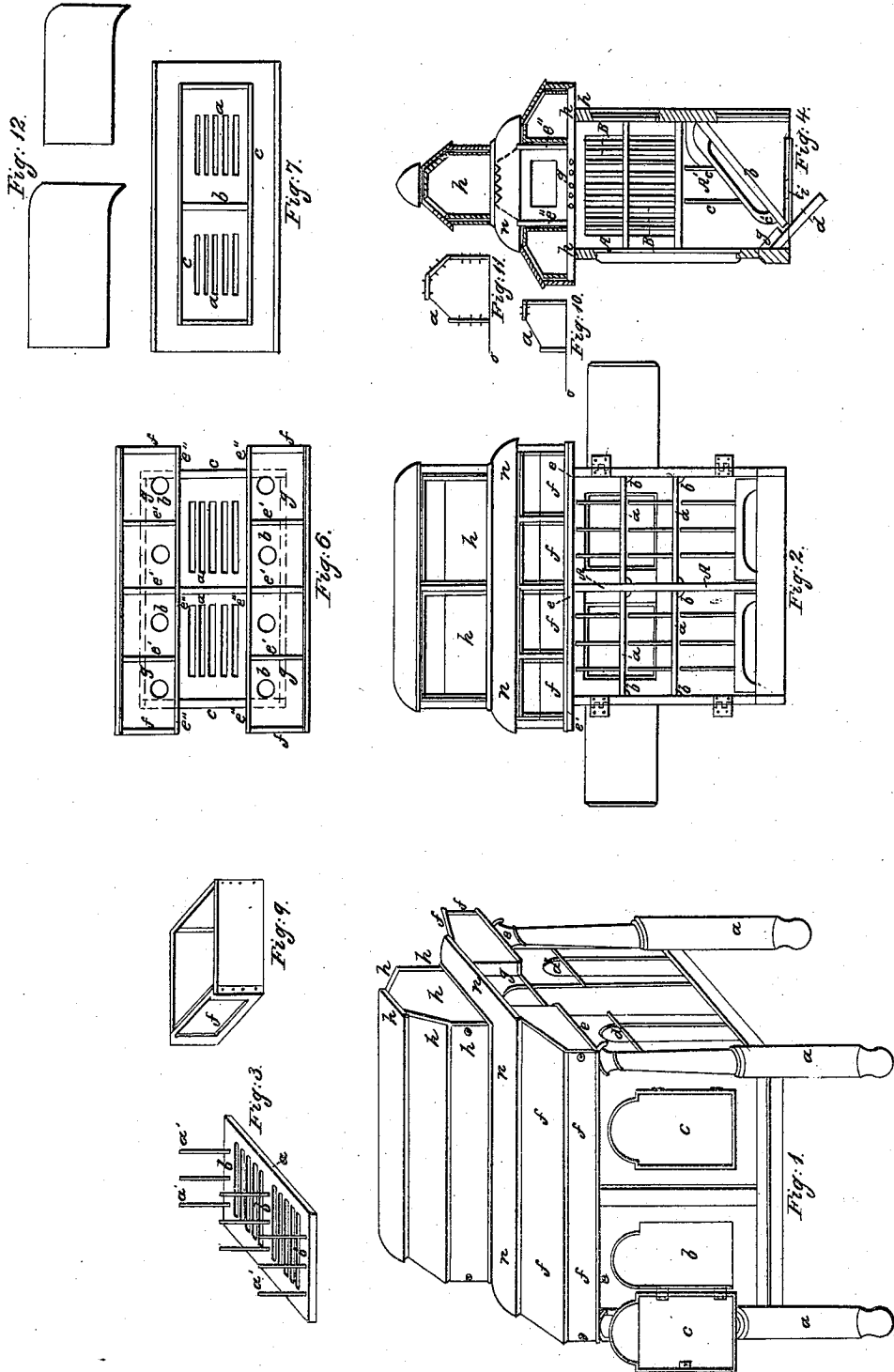

No. 1,555.

UNITED STATES PATENT OFFICE.

MARTIN ENGEL, OF EASTON, PENNSYLVANIA.

BEEHIVE.

Specification of Letters Patent No. 1,555, dated April 15, 1840.

To all whom it may concern:

Be it known that I, MARTIN ENGEL, of the borough of Easton, in the State of Pennsylvania, have invented a new and useful
5 Improvement in the Manner of Constructing Beehives, which improved hives I denominate the "bee-palace;" and I do hereby declare that the following is a full and exact description thereof.

10 In the accompanying drawings Figure 1, is a perspective view of the hive, in the form in which I ordinarily make it. Fig. 2, is a front view of the body of the hive, the exterior case being opened, or removed, for
15 the purpose of showing the interior. Fig. 4 is a vertical section of the hive from front to back.

The dimensions of this hive may be varied, but those which I shall give I consider
20 as furnishing a good ordinary size.

The body of the hive I make two feet eight inches wide, and two feet four inches high, and one foot six inches deep from
25 front to back. This body is supported at the corners by the columns or legs *a, a*, Fig. 1.

I divide my hive, lengthwise, into two compartments by means of a partition extending from top to bottom, and front to
30 rear. This partition is seen edgewise at *A, A* Fig. 2, and flatwise at *A A'*, Fig. 4. The lower portion of it, *A'*, is solid, the upper part is perforated so as to constitute a grating *B, B*, with vertical bars, between
35 which the bees may pass freely from one compartment to the other, when it is desired that they should do so; but when the numbers are small, and it is desirable to confine them to one compartment, these grate
40 bars may be covered by sheets of iron or of tin plate which are shown, and marked Fig. 12. These plates are used also to cut, or separate the comb when it is desired to remove the honey from one of the divisions
45 of the hive, of which there are several.

Each of the compartments formed by the partition *A, A*, is divided into three chambers by means of horizontal sliding shelves, formed as chosen in Fig. 3. These shelves
50 have gratings formed of bars which may be half an inch wide, and the same distance apart, leaving openings similar to those in the vertical partition *A A*. From the frame *b, b*, of these shelves rise vertical rods or
55 building sticks, of wood *a', a'*, which come nearly into contact with the shelf or floor

above them; they are about eight inches long, and serve the purpose of building sticks to support the comb and for the bees to pass up. These shelves slide in and out
60 upon ledges or cleats, marked *b, b*, Fig. 2, and they extend from front to back of each compartment. The lower chamber, beneath the lower sliding shelves, has an inclined bottom, as shown at *b*, Fig. 1, upon which
65 there is a frame *c'*, which supports vertical rods or climbing and building sticks *c, c*, similar to those on the shelves *a, a*, Fig. 2; these sticks rise to within about an eighth of an inch of the lower sliding shelves. The
70 inclined bottom *b*, is about eighteen inches wide; its lower edge extends to within three or four inches of the back of the hive, where it comes nearly into contact with a second inclined or traveling plane *d*, which
75 is about nine inches wide, and stands like the former the whole width of the hive. Between the upper side of the plane *d*, and the edge of the plane, *b*, there is an aperture of about an inch for the passage of the bees.
80 Upon the upper side of the inclined plane *d* I affix a narrow strip *g*, the edge of which comes within half an inch of the upper side of the plane *b*, by which means an abrupt change is made in the direction of the entrance, obliging the bees or other insects to
85 turn about in entering, and thus affording a decided advantage to the inmates of the hive in attacking intruders.

For the purpose of closing the entrance
90 aperture at night, when it may be thought desirable to protect the bees, I place a sliding strip or shutter *i*, which may be made to cover the opening or entrance, between the inclined planes.
95

In Fig. 1, *e, e*, are doors, which may be either hinged or made to slide as preferred, these doors cover panes of glass *v*. On the opposite side of the hive there are also
100 panes of glass which are covered by hinged or sliding doors; these afford a view of the interior when required, and access thereto may be obtained by making the glass removable. There are openings at each end of the hive, as at *d, d*, Fig. 1, which are
105 closed by shutters, giving the means of ventilation when said shutters are removed.

Having thus described the manner in which I construct and arrange the body or lower part of my hive, I now proceed to describe the upper stories, or parts above the
110 body, which, however, may be varied in

form but that given I have essayed, and found to answer well in practice. The main floor, or dividing platform, between the body of the hive and the upper stories, as shown in Fig. 6; the dotted lines *g, g*, represent the upper edge of the body, to which the floor is to be secured; the edges of this floor are seen at *h, h*, Fig. 1, and at *e, e*, Fig. 2, likewise *e, e*, Fig. 1. It is three feet 10 two inches long, and two feet two inches wide. At *e, e*, Fig. 6, the floor is nine inches shorter than at its sides, for the purpose of constituting sheltered recesses at the ends of the hive, as seen in Fig. 1. The middle part 15 of this floor is provided with grate bars, *a, a*, the openings between which allow the bees to ascend from the two compartments in the body, into that shown at *g*, Fig. 1. Two sliding boxes or drawers having neither 20 tops nor bottoms, occupy the compartment *g*, one being slid in at either end of the hive, as at *g*, Fig. 1. These two drawers meet at the middle of the compartments, and their outer ends *f* Fig. 9 are to be 25 glazed to admit of inspecting the interior; these drawers are contained between two upright partitions marked *e'', e''*, Figs. 6 and 4; and there are, outside of these, cross partitions *e', e', e'*, which divide each of 30 the gable spaces *f, f*, Figs. 1, and 2, into four or any other convenient number of compartments, each of which contains a box filling said spaces. Fig. 10, shows the end of one of these boxes; a strip of glass at *a* 35 Fig. 10, is inserted along them, they are without a bottom, and stand over the holes *b, b, b*, in the floor Fig. 6, through which holes the bees have access to them, for build-

ing their combs; they are seen in place at *f, f*, Fig. 2. Above the compartment *g*, Figs. 40 1, and 4; there is another marked *k*, which contains two boxes without bottoms seen at *h, h*, Fig. 2, and in end view at Fig. 11, furnished with a strip of glass at *a*. Fig. 7, is the floor of these compartments, having 45 grates at *a, a*. This floor I prefer to make of thick plank for the purpose of obtaining a rounded eave, as shown at *n, n*, Figs. 1, 2 and 4.

Having thus fully described the manner 50 in which I construct my beehive or bee palace, it is to be understood that I have included in said description many things which I do not claim as new, and to the particular form and manner of constructing 55 which I do not intend to limit myself; but

What I do claim as my invention and desire to secure by Letters Patent, is—

1. The manner in which I have combined and arranged the two inclined traveling 60 planes *b*, and *d*, and the strips *g*, Fig. 4 for the entrance of the bees, so as to form the abrupt turn as shown in the drawings.

2. I claim in combination with said entrance, the closing slide *i*, shown in Fig. 4. 65

3. I claim also the manner of constructing and using the sliding frames, Fig. 3, with their vertical rods, climbing, or building sticks; and also the constructing of the horizontal grates in the manner and for the 70 purpose set forth.

MARTIN ENGEL.

Witnesses:

GEO. BUSH,
GEO. SIGMAN,