

B. H. REESE,  
Bee Hive.

No. 35,892.

Patented July 15, 1862.

Fig. 2.

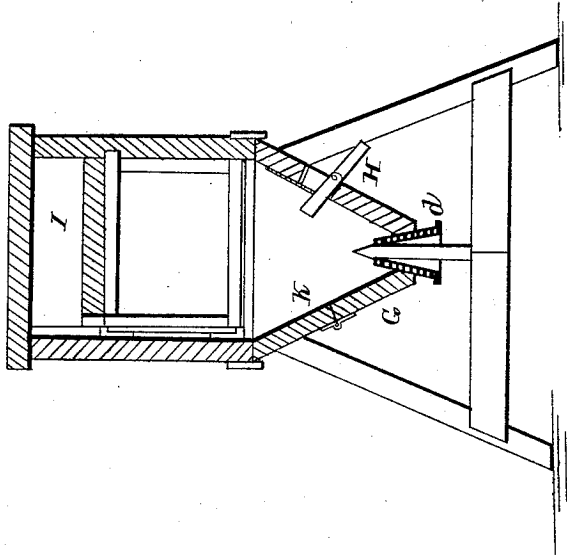
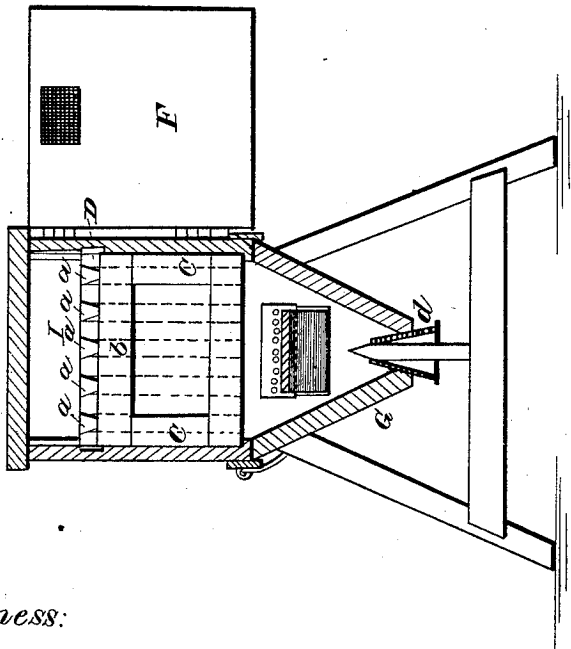

Fig. 1.



Witness:

Charles Alexander

Inventor:

B. H. Reese  
by J. H. Alexander atty.

# UNITED STATES PATENT OFFICE.

B. H. REECE, OF MARION, IOWA.

## IMPROVEMENT IN BEE-HIVES.

Specification forming part of Letters Patent No. 35,892, dated July 15, 1862.

*To all whom it may concern:*

Be it known that I, B. H. REECE, of Marion, county of Linn, and State of Iowa, have made certain new and useful Improvements in Bee-Hives; and I do hereby declare that the following is a true and exact description of the same, reference being had to the accompanying drawings, and to the letters of reference marked thereon.

Figure 1 in the annexed drawings represents a vertical section of the hive, in connection with the frame or stand upon which it rests.

The letters *cc* represent the edges of the side boards, with grooves cut in them sufficiently deep to receive the movable glass door *b*.

The letter *E* designates the cross-tie binding the two sides of the hive together, and having the ends flush with the bottom of the grooves, so as not to interfere with the proper position of the glass door *b*. Into this cross-tie the movable frames *a a a a* are loosely dovetailed, so that each can be drawn out of the hive without disturbance to the bees.

*F* represents the door of the hive with a hole near the top, with a wire grating over it to admit the air and exclude the moth.

*d* is a funnel-shaped moth-slide, made of tin or other metal, and placed at the bottom of the stand *G*, with its upper end penetrating a hole made for its admission, and may at pleasure be elevated or depressed upon the stem, which passes through its center. This moth-slide

when lowered admits the bees, and when raised excludes the moth, and being perforated with small holes, allows a free circulation of air.

The letter *H* in Fig. 2 represents a platform inserted into the side of the stand *G* at an angle of forty-five degrees and playing upon hinges, so that by elevating or lowering the lower end the aperture through which it enters the stand can be opened or closed.

*I* represents the open space above the frames *a a a a*, and forms a separate bee chamber, with an opening at the edge for the admission of the bees from below.

*K* is the door intended for the convenience of cleaning the stand.

Having thus fully described my invention, what I claim, and desire to secure by Letters Patent, is—

1. Supporting or hanging the movable frames *a a a* by means of dovetails, in order that they may be easily and expeditiously removed without irritating the bees, substantially in the manner set forth.

2. The moth-slide *d*, when employed in conjunction with frames *a a a* and movable glass door *b*, the whole being constructed and arranged in the manner and for the purpose specified.

B. H. REECE.

Attest:

N. W. ISBELL,  
JOHN MITCHELL.