

A. P. BLAKE.
Centrifugal Ventilator.

No. 46,067.

Patented Jan'y 31, 1865.

Fig. 1

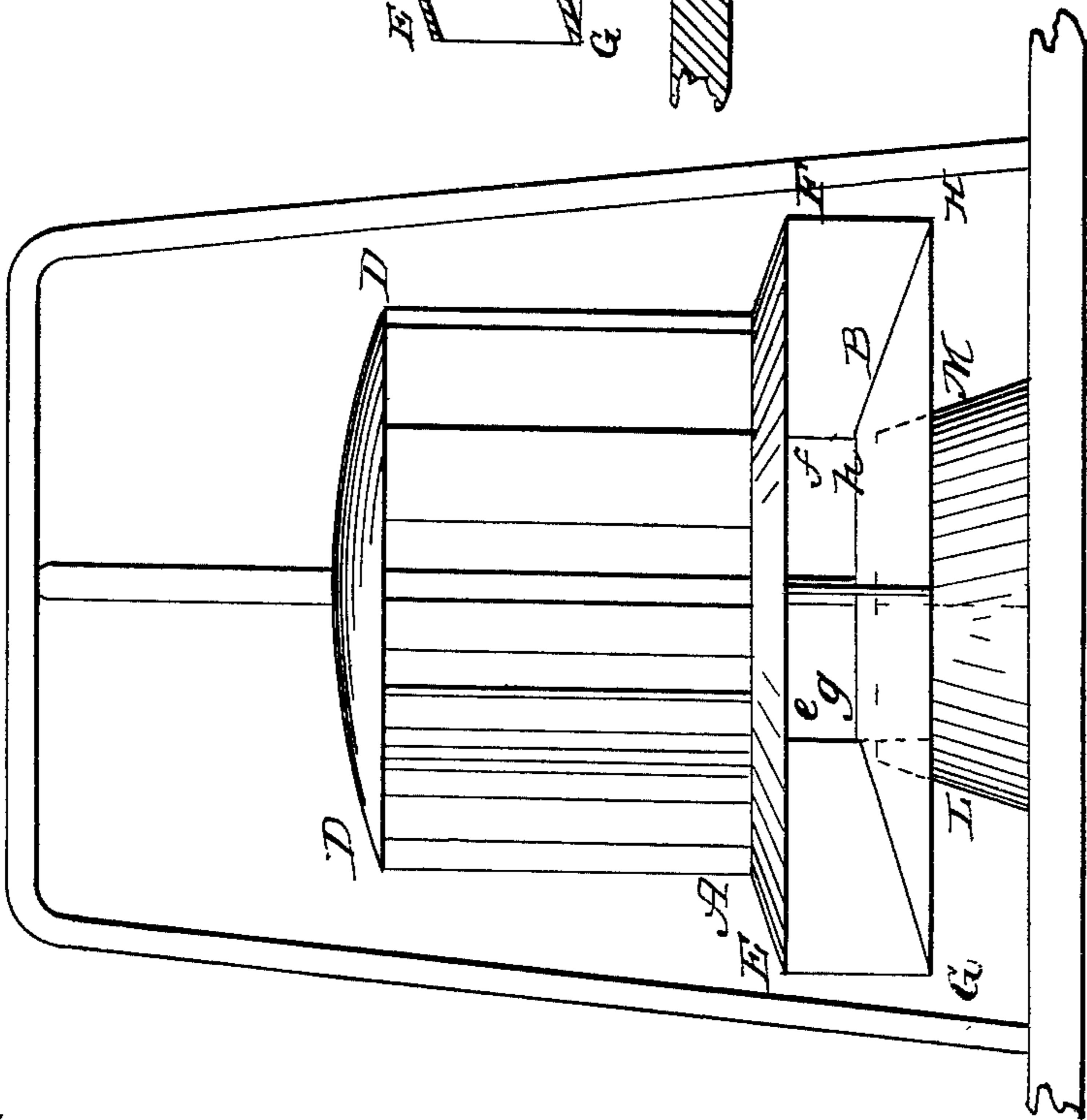
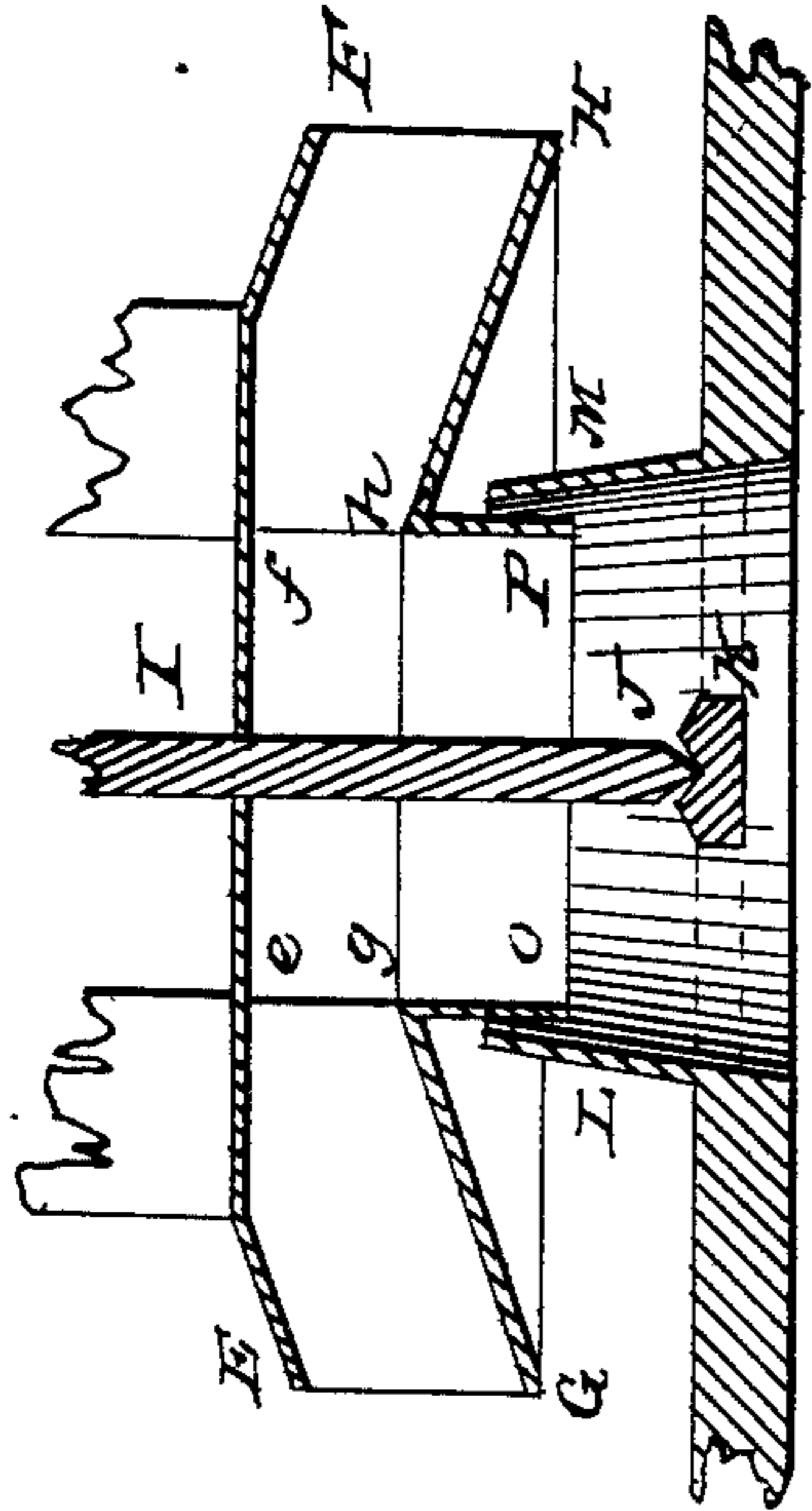

Fig. 2



Witnesses
J. Herbert Hedd
William Edson,

Inventor
A. P. Blake

A. P. BLAKE.
Centrifugal Ventilator.

No. 46,067.

Patented Jan'y 31, 1865.

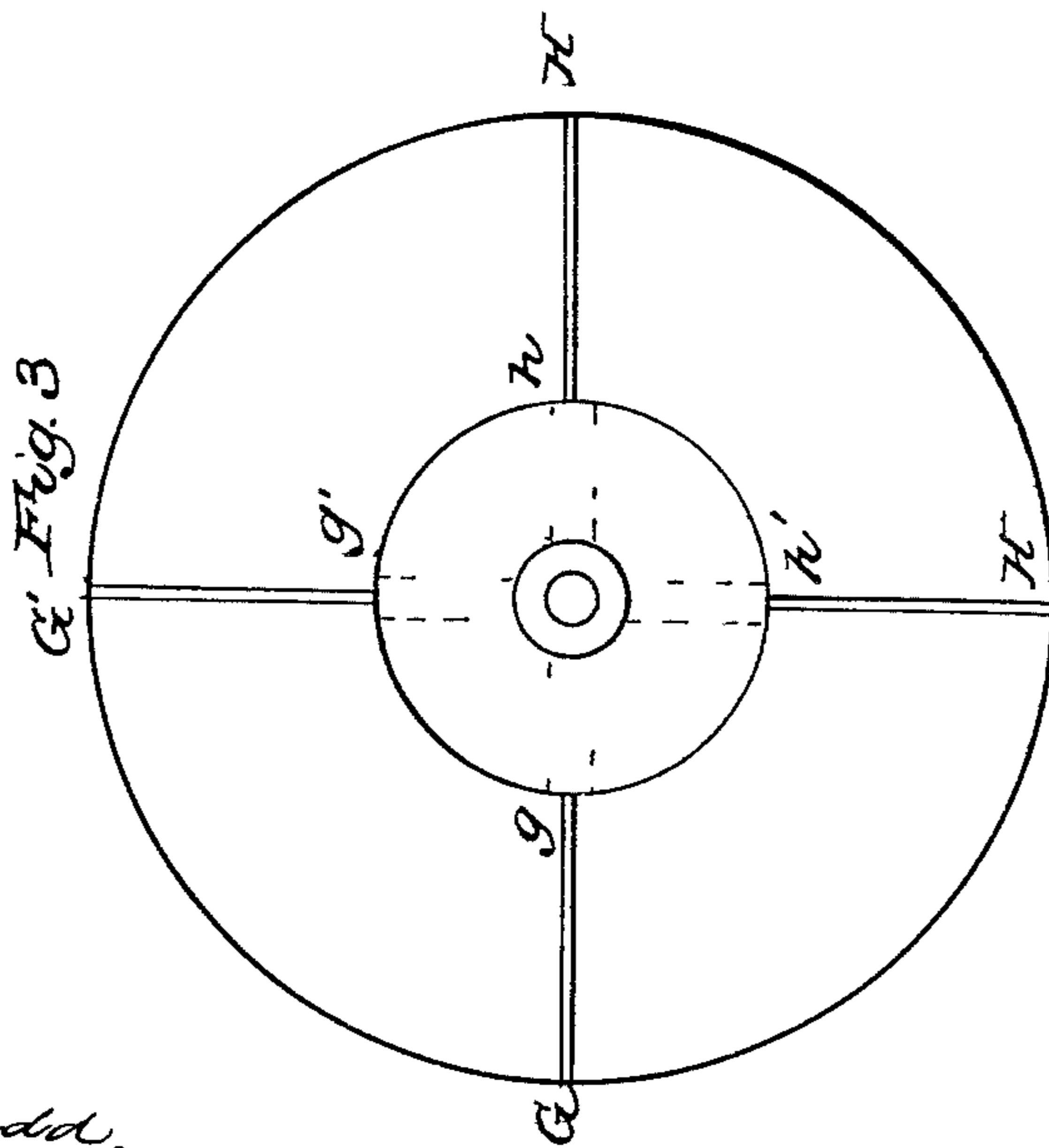
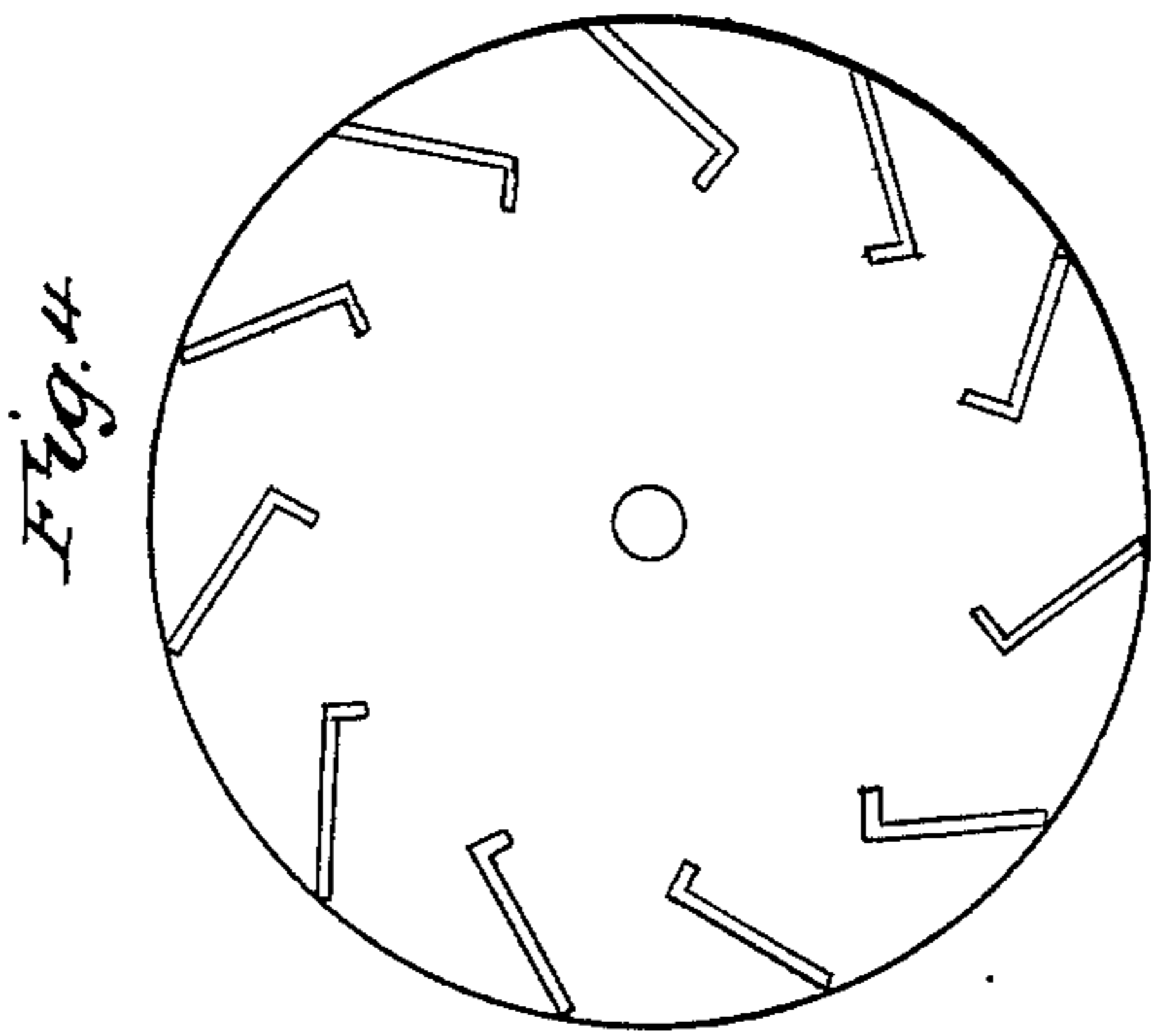

Witnesses
Herbert Shedd,
Melvin Edson,

Inventor
A. P. Blake

UNITED STATES PATENT OFFICE.

ALPHEUS P. BLAKE, OF MILTON, MASSACHUSETTS.

CENTRIFUGAL VENTILATOR.

Specification forming part of Letters Patent No. 46,067, dated January 31, 1865.

To all whom it may concern:

Be it known that I, ALPHEUS P. BLAKE, of Milton, in the county of Norfolk, State of Massachusetts, have invented a new and Improved Centrifugal Ventilator; and I do hereby declare that the following is a full and exact description thereof, reference being had to the accompanying drawings, and to the letters of reference marked thereon.

The nature of my invention consists in the combination of a vertical windmill or propelling head with an improved centrifugal exhaust wheel or ventilator.

To enable others skilled in the art to make and use my invention, I will proceed to describe it.

Drawing No. 1, elevation; No. 2, vertical section through exhaust wheel; No. 3, horizontal section of exhaust wheel; No. 4, horizontal section of propelling head or windmill.

A B C D in No. 1 is a vertical windmill. The form of the buckets or fans are shown in section on No. 4. E G e g in Nos. 1 and 2, and in section G g G' g' H h H' h' in No. 3 are fans or blowers of exhaust wheel. These fans, as shown, do not extend from the circumference to the center, but are cut off at a certain distance from the central shaft, for the purpose of securing additional efficiency for exhaustion when in motion, and for allowing a free passage of air when the wheel is at a rest.

E e F f in No. 2 is an upper head or disk of exhaust wheel, extending, as shown, beyond the circumference of the wind-wheel. This extension of the upper and lower disks with the fans beyond the wind-wheel gives a greatly increased power to the ventilator.

G g H' h' in Nos. 1 and 2 and G H' H G' in No. 3 is the lower disk of exhaust wheel, provided with a large orifice, as shown at g h' h g' in No. 3. The circumference of the orifice

limits the extension of the fans toward the center, as shown at No. 3.

I J in No. 2 is a shaft, supported at the lower end by the foot pan K and at the upper end by any suitable arch or frame, the lower ends of which are attached to the chimney, ventilating-flue, or building, as shown on No. 1.

L M in Nos. 1 and 2 is a circular and slightly conical top piece of chimney or flue; O g h P in No. 2, a tube attached to and extending down from the circumference of the orifice in the lower disk into the top piece, L M. The object of this last combination is to prevent the passage of air into the vacuum in the exhaust wheel from any source other than the proper one through the chimney or air flue.

The office and action of my invention is this: It is placed over any chimney, air flue, or opening from which it is desirable to draw air, smoke, or gas. Any breeze acting upon the windmill will cause it to turn. The exhaust-fans will revolve rapidly, and, throwing off the air from the extremities, will cause a vacuum to form in the center, which must be supplied from the chimney, air flue, or opening over which the instrument is placed.

What I claim as my invention, and desire to secure by Letters Patent, is—

1. The arrangement of the fans or blowers of the exhaust wheel.
2. Incasing the fans or blowers at the top and bottom.
3. The combination and arrangement of the fans, disk, and wheel, as shown in section in No. 2, all of which substantially as described and for the purpose set forth.

A. P. BLAKE.

Witnesses:

J. HERBERT SHEDD,
WILLIAM EDSON.