

J. W. Winder,

Bee Hive.

No. 103697.

Patented May 31. 1870.

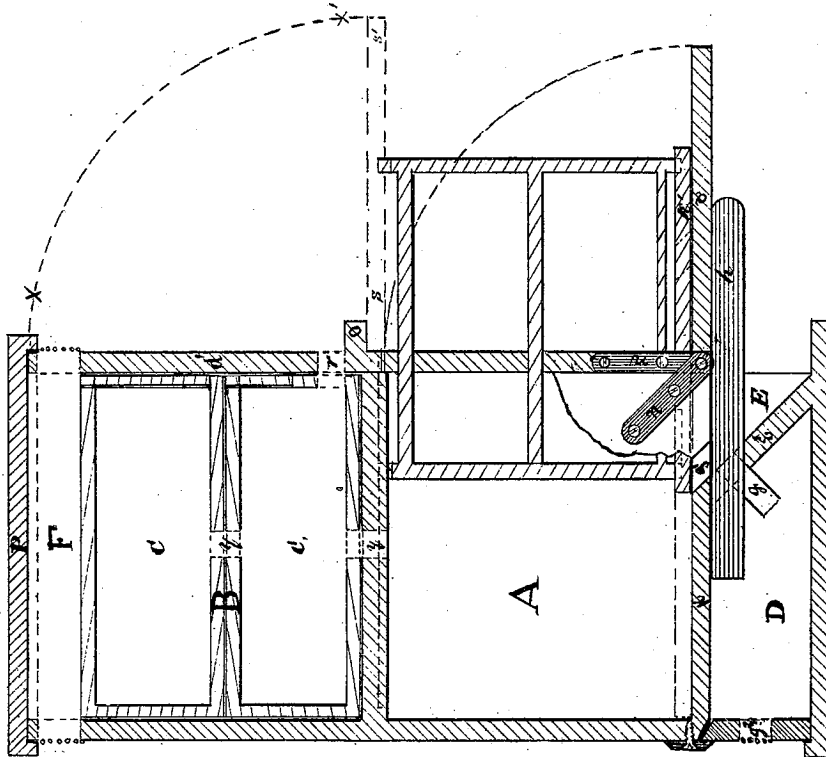
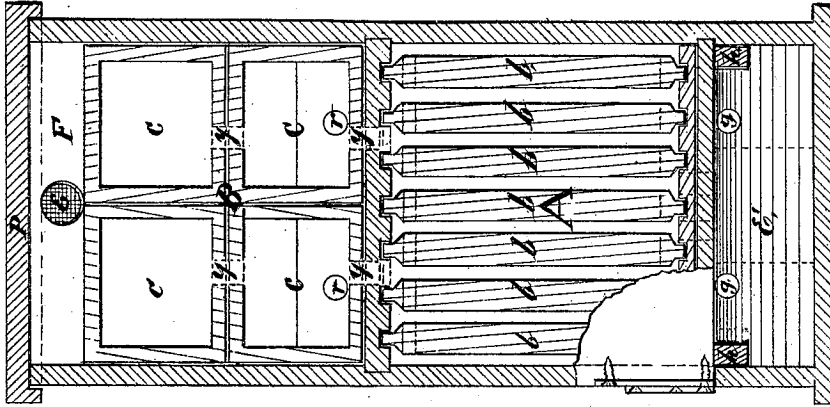

Witnesses — *R. C. Wood*
J. Finlton

Inventor
J. W. Winder

United States Patent Office.

JOHN W. WINDER, OF CINCINNATI, OHIO.

Letters Patent No. 103,697, dated May 31, 1870.

IMPROVEMENT IN BEE-HIVES.

The Schedule referred to in these Letters Patent and making part of the same.

I, JOHN W. WINDER, of Cincinnati, in the county of Hamilton and State of Ohio, have invented certain Improvements in Bee-Hives, of which the following is a specification.

Nature and Objects of the Invention.

The nature of my invention consists in constructing a bee-hive in four compartments; one of which is the main hive, which is independent of the other divisions, and is provided with movable frames sliding in grooves at the top, and resting on a false movable bottom, which, by its construction, admits of one, any, or all of the comb-frames in the main hive being removed and replaced at pleasure.

The second compartment is a moth-chamber underneath the main hive, in front of which is a recess, providing a lighting-board for the bees, and having ports or holes for the entrance of moths into this chamber; also, other holes completely protected from the weather, leading into the hive, for the entrance of the bees.

The third compartment is a surplus-chamber, arranged to enlarge the capacity of the hive, and receive suitable boxes which can be adjusted or removed without disturbing the main hive by opening a drop-door.

The fourth compartment is an air-chamber above the surplus or box-chamber, and covered with a lid, which, by the arrangement, holds the door in position when closed.

The nature of this invention further consists in providing slats for the main hive to rest upon when open, and to support the comb-frames thereof when drawn out.

This invention also relates to a hinge adapted to a drop-door, which is cheap and of easy construction, as well as strong and durable.

Description of Accompanying Drawings.

Figure 1 is a vertical cross-section, showing the comb-chambers partially drawn out.

Figure 2 is a front elevation of the hive.

General Description.

A is the main hive, beneath which is the miller-box D, which is a tight, stationary compartment.

E is a recess in front of the chamber D, and underneath the front part of the main hive A.

E' is the lighting-board which forms the front of the moth-chamber D.

g g are small ports for the entrance of moths into chamber D.

g¹ is the bee-entrance into the main hive.

k is the bottom of the main hive.

k is a false bottom with gains cut for the frames b to rest in.

The frames b b are made with tenons on the top sliding in grooves t, and fit in gains cut in the false or movable bottom k. These grooves and gains hold the comb-frames in the proper position. When drawn out they are easily detached by lifting the tenons out of the front gains.

d is a drop-door working on hinge n.

h h are slats fitting in gains cut in the lighting-board E, and are run back into the moth-chamber, so as to be out of the way when not in use. When drawn out, as shown in fig. 1, they support the door d on which the false bottom k rests when drawn out.

b b are movable comb-frames of the main hive.

B is the surplus or box-chamber or compartment.

y is the entrance from the main hive.

r r are entrances from the front, and may be closed by the use of a slide or other devices, or left open for the passage of the working bees, without having to pass through the main hive.

d' is a drop-door with a cleat O projecting at right angles. When this door is open the cleat is brought against the face of the lower door d, holding the door d in a horizontal position, level with the plane of the lower boxes c c, forming a table for the boxes to rest upon when drawn out of chamber B. In fig. 1 the door d' is closed; the dotted lines s s' show the position of this door when open, and the curved line of dots x x' shows the arc of circle described by it in opening or closing.

The lower door d is represented as open, resting on the slats h h, with dotted lines showing its sweep.

F is an air-chamber above the hive, with holes e e for ventilation and absorption of moisture, keeping the hive cool in summer and dry in winter.

P is the cap which covers the top of the hive, and has projections or lips to hold the door d' in position when closed.

The hinge n is composed of two strips of metal with holes drilled for the screws. The center screw is fastened or screwed into the door, as shown at n in fig. 1, and serves as a pivot for both strips to revolve upon, and can be attached at any angle, being cheap of construction, stronger and more durable than other hinges adapted to similar purposes.

The hive constructed as described has many advantages over ordinary hives.

The moth-chamber is easily made, and, being immediately beneath the hive, economizes space, while furnishing a place for the moths to deposit their ovum. The lighting-board, being placed at a desired angle, allows the bee-entrance to be made from underneath the hive-chamber protected from the atmosphere, and

more secure from insects, while the relative arrangement of the moth-ports and bee-entrance is such that hive-robbers will be more likely to enter the moth-chamber than the hive.

The rear port of the moth-chamber g^2 should be covered either with wire gauze, or glass, to admit light and attract moths and hive-robbers to the rear of the port g , which, being placed at the angle shown, the chamber acts as a trap, from which the insects may be removed through the door in the rear.

By the use of the false bottom and movable comb-frames, one, any, or all of these frames can be removed to take out the comb or moths that may have entered the main hive, thereby dispensing with hooks, pins, or other devices now in common use for this purpose.

Sufficient space is allowed around the comb-frames for the bees to pass while at work.

The main hive can be separated from the surplus-chamber by slats, instead of a division-board, as shown

in the drawing. Likewise slats may be used to support the movable bottom k .

Claims.

I claim as my invention—

1. The combination of the chamber A, frames $b b$ with the sliding bottom k and drop-door d , and slats $h h$ arranged above the recess E, and moth-chamber D, substantially as herein set forth.

2. A hive, when composed of the compartments A B and D, with the doors $d d$ and slats $h h$, constructed and arranged substantially as herein set forth.

3. A hive composed of the chamber A, movable frames $b b$, and bottom k , supported by the slats $h h$, when combined with the chamber B, constructed and arranged as herein shown.

Witnesses:

JOHN W. WINDER.

J. FULTON,

E. E. WOOD,

E. BOYD.