

(Model.)

J. T. FIFE & L. E. MERCER.

BEE HIVE.

No. 271,197.

Patented Jan. 23, 1883.

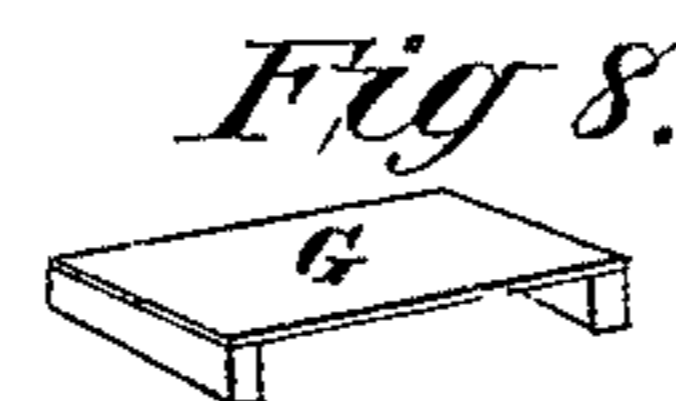
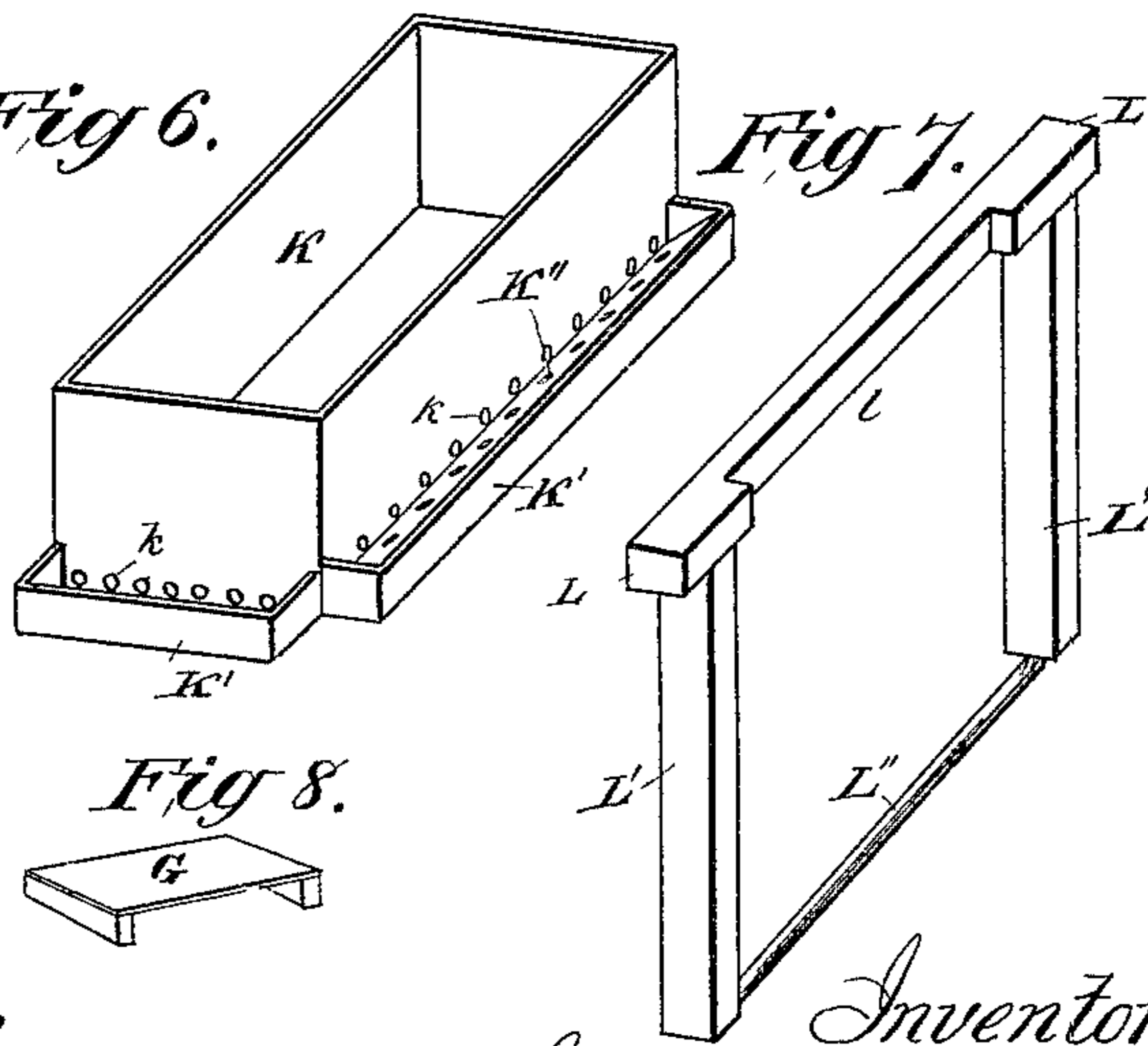
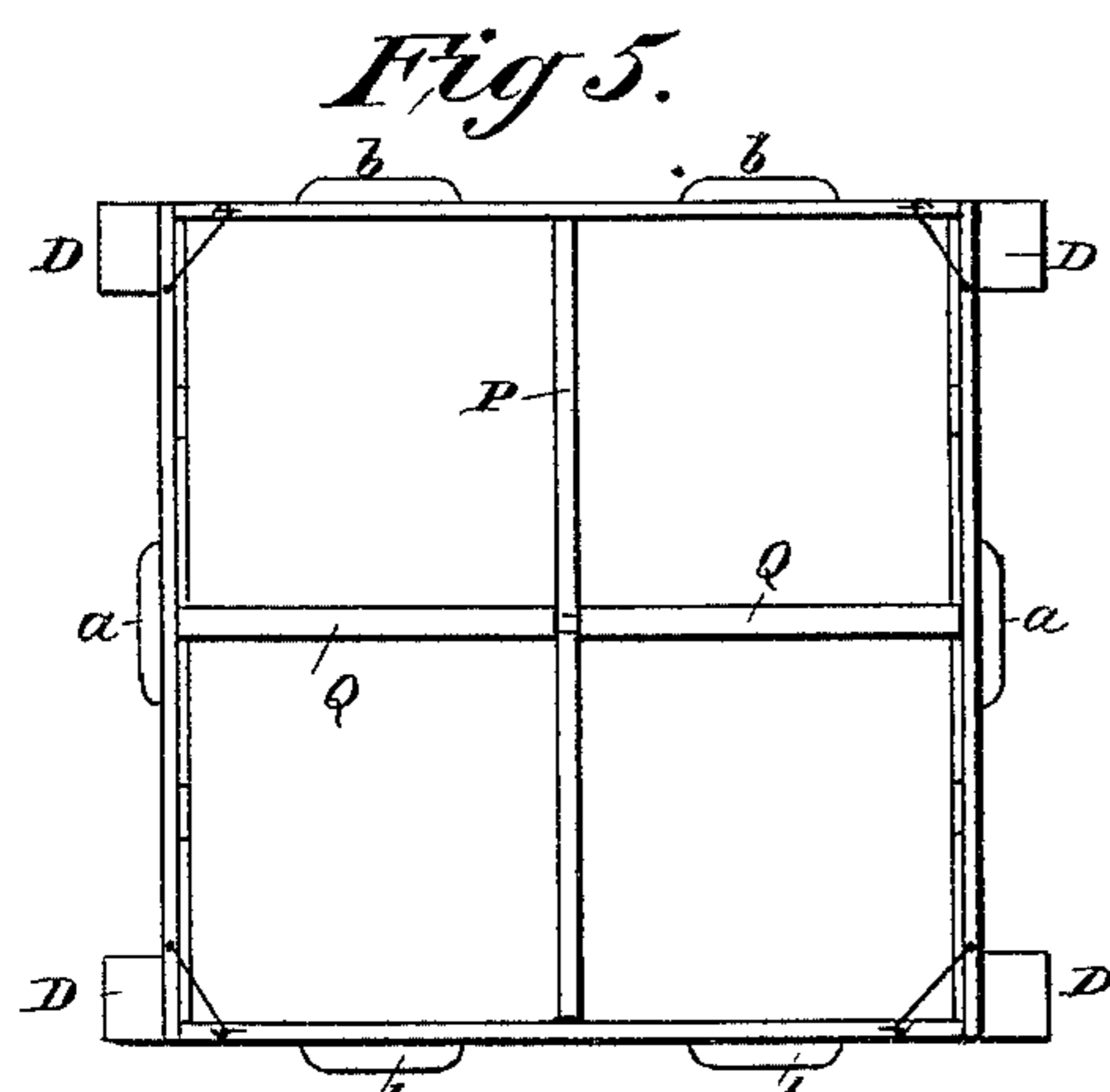
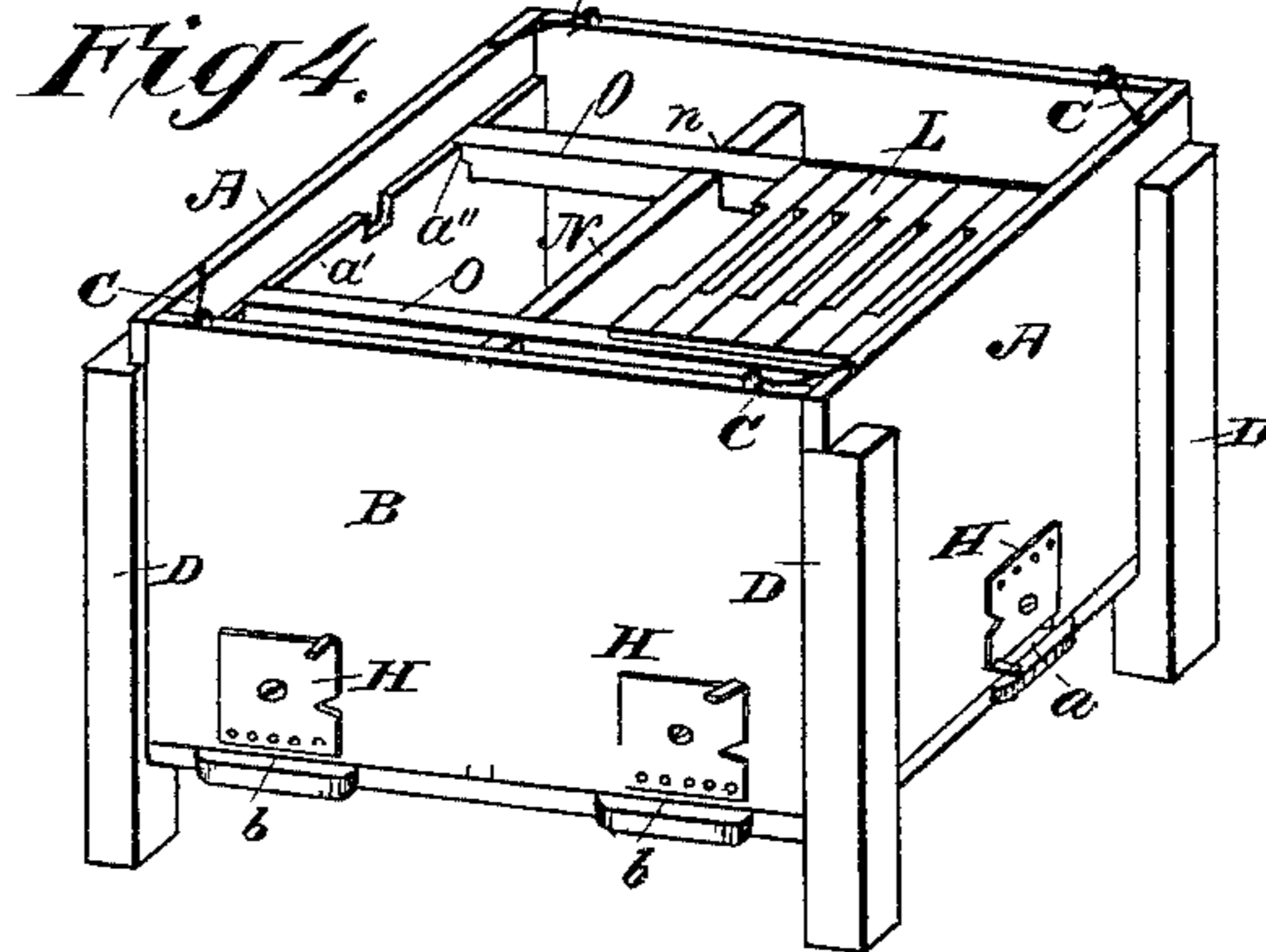
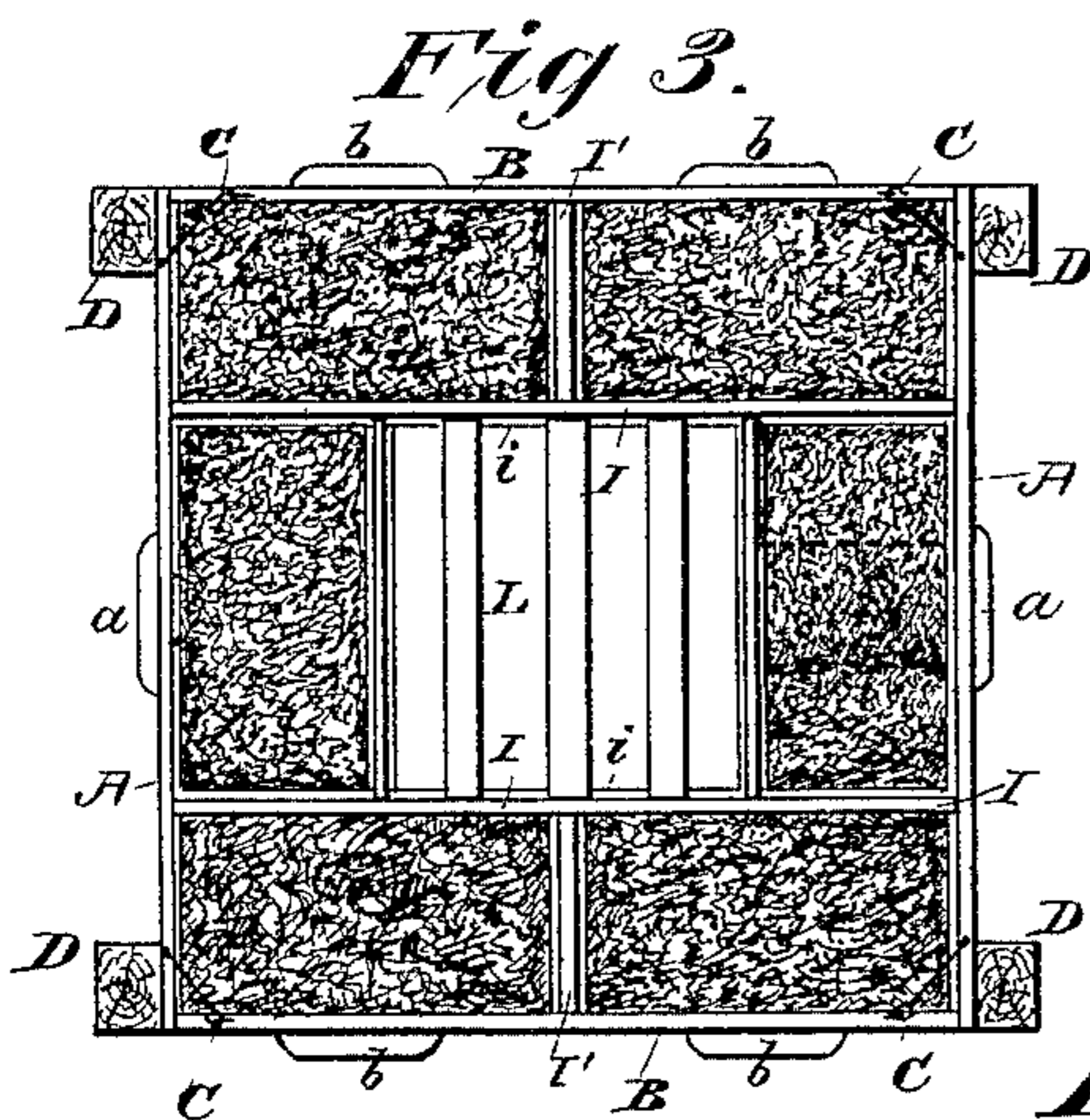
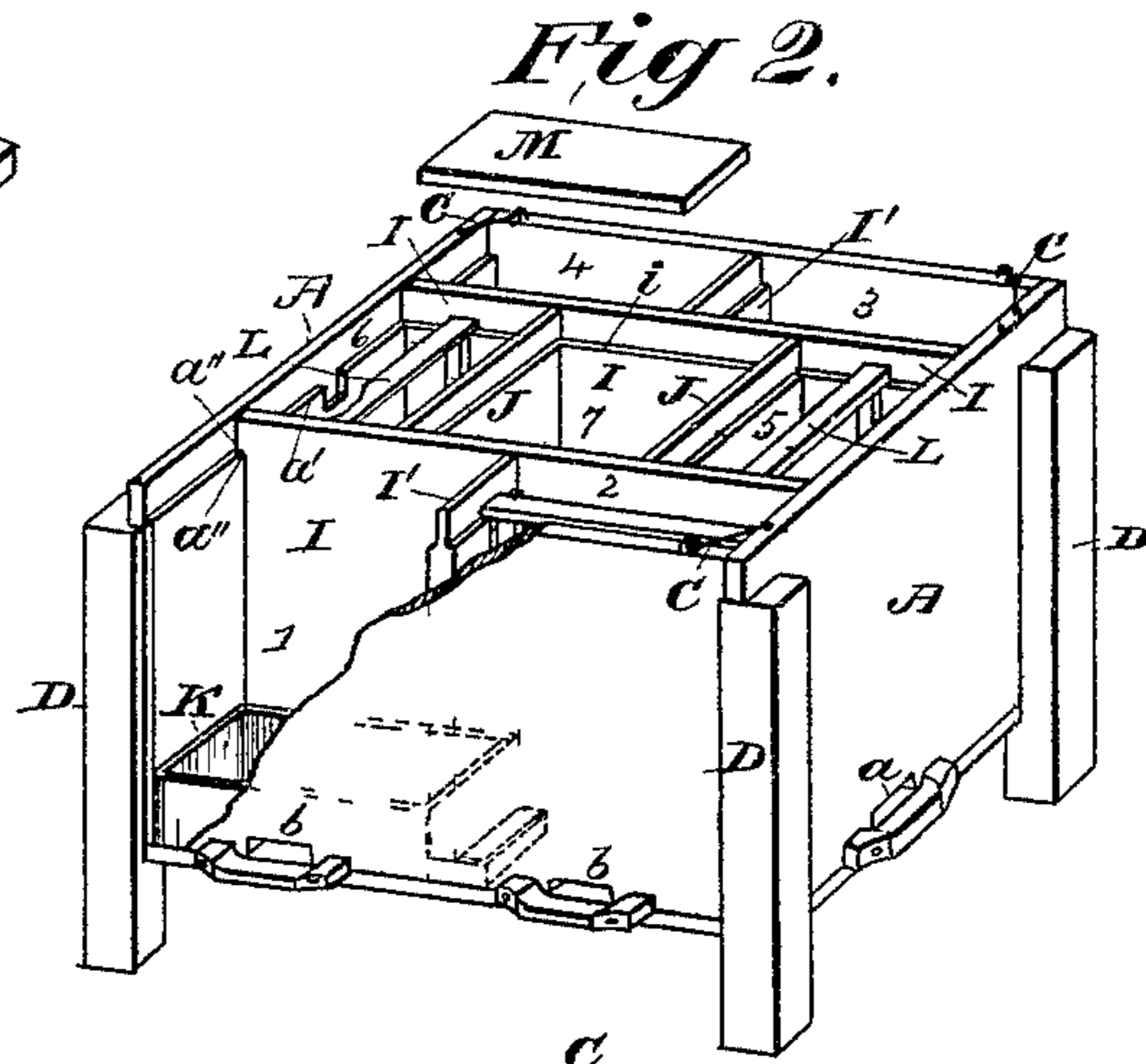
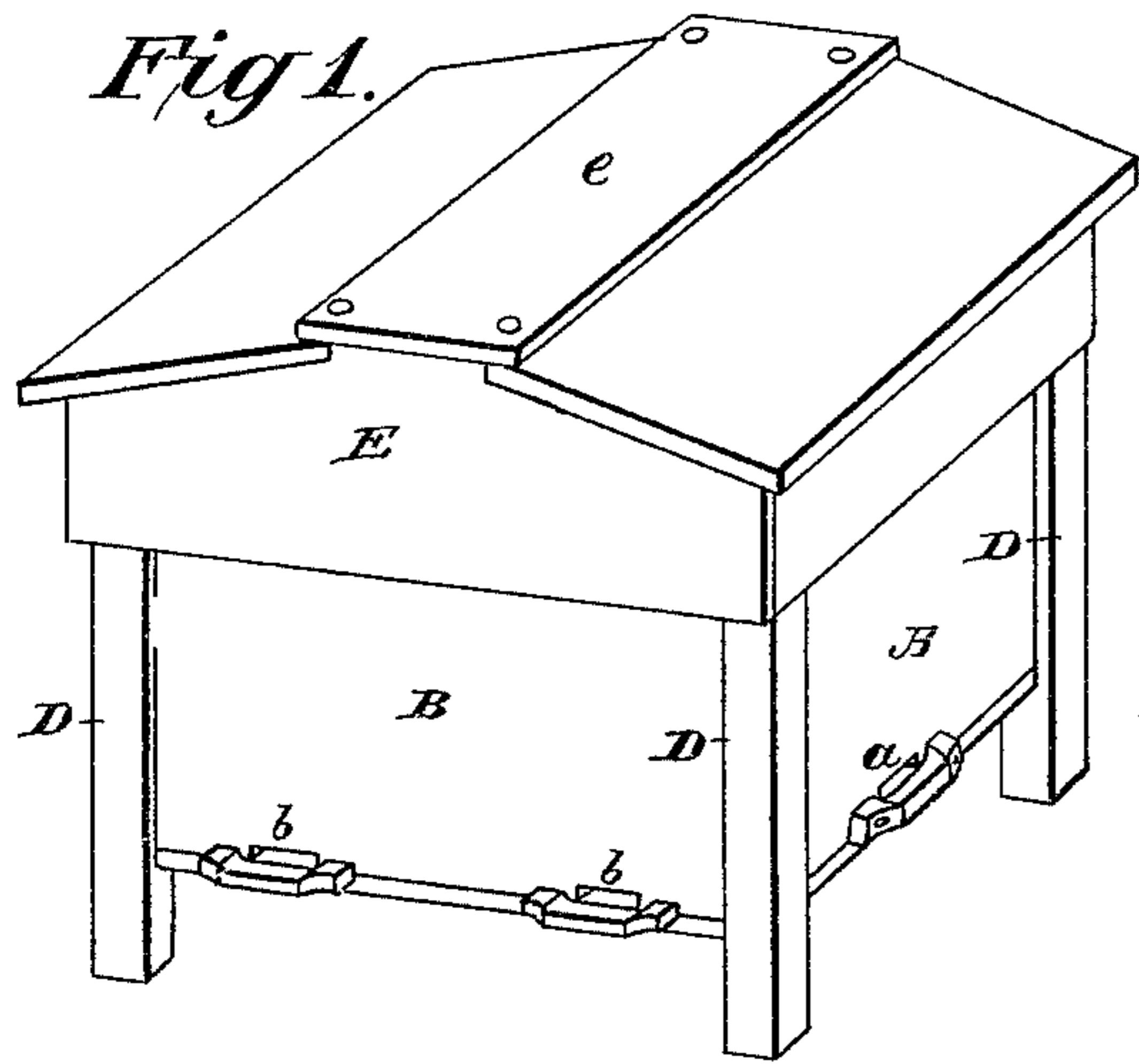

Attest { Geo. T. Smallwood Jr.  
L. M. Hopkins.

Inventor:  
James T. Fife and  
Lemmon E. Mercer  
BY Knight Bros.  
attys.

# UNITED STATES PATENT OFFICE.

JAMES T. FIFE, OF CORNING, AND LEMMON E. MERCER, OF LENOX, IOWA;  
SAID FIFE ASSIGNOR TO SAID MERCER.

## BEE-HIVE.

SPECIFICATION forming part of Letters Patent No. 271,197, dated January 23, 1883.

Application filed December 12 1881. (Model.)

*To all whom it may concern:*

Be it known that we, JAMES T. FIFE and LEMMON E. MERCER, citizens of the United States, residing respectively at Corning, in the county of Adams, and at Lenox, in the county of Taylor, both in the State of Iowa, have invented new and useful Improvements in Bee-Hives, of which the following is a specification.

The invention consists in combining with a rectangular hive having suitable entrances and notches or bearings in its sides various partitions, feeders, &c., to adapt the hive for different uses, as for breeding queens, for making honey, for a winter-hive, or for accommodating and feeding two or more swarms in the same hive, as hereinafter described.

In the accompanying drawings, Figure 1 is a perspective view of our improved hive. Fig. 2 is a perspective view of the same with the top removed and the internal partitions so arranged as to divide the hive into seven compartments. Fig. 3 is a top view of the same as prepared for use as a winter hive. Fig. 4 is a perspective view of the hive having its partitions so arranged as to accommodate two swarms. Fig. 5 is a top view of the hive divided into four compartments. Fig. 6 is a perspective view of our improved feeder. Fig. 7 is a perspective view of our honey frame. Fig. 8 represents the bridge used in the winter-hive.

A A represent the two stationary sides of our improved hive, and B B two removable sides, which may be hinged at their base and held to an upright position by means of hooks C on the stationary sides engaging with staples on the movable sides.

D are corner-posts which serve as braces for the sides of the hive, and extend somewhat below the same for use as legs. These posts are cut away below the top of the sides, and on them rests the removable cover E, which has a cap piece, e, screwed in place, and capable of being removed for the purpose hereinafter set forth. Each stationary and removable side of the hive has either a single entrance, a, at its middle, or two entrances, b b, at a suitable distance apart.

In Fig. 4 we have also shown, at H, a shutter with ventilating-holes applied to the bee-entrances. Each stationary side A has a shoulder or ledge, a', near its upper edge, for supporting the ends of partitions or honey-frames.

The interior of the hive may be divided off in various ways to suit the hive for any use to which temporarily it is to be applied. For example: To run four swarm nuclei in one hive, with feeding-troughs for each nucleus and an apartment at the center in which either to store tools, brushes, feathers, queen-cages, &c., or to run another large swarm, we arrange the hive and partitions as shown in Fig. 2. To put the hive together in this form, the movable sides B B being in place, we proceed as follows: We place the two long partitions I in place so that projections on their upper ends shall engage in notches a'' in the sides A. When in this position two short partitions, I', about six inches in width, which are affixed to near the middle of the partitions I, will divide the spaces between the two partitions I and the respective movable sides B into four compartments. The inner sides of partitions I are provided with the shoulders i at the same distance from the hive-bottom as the shoulders a' on the sides A. Between the partitions I, and resting by their end projections on shoulders i to prevent them from falling, we place short partitions J J at a distance of about six inches from the respective sides A A. The seven compartments into which the hive is now divided we have numbered from 1 to 7. Of these, two compartments, 1 and 3, in opposite corners, are made smaller than the chambers 2, 4, 5, and 6. In these compartments 1 3 we place feeders, preferably of the form shown in Fig. 6. These feeders consist of a reservoir, K, in which any desired quantity of food may be placed, and feeding-troughs K', which project through cut-away portions in the bottoms of partitions I and I', so as to permit access of the bees in any of the chambers 2, 4, 5, and 6 to the feeders. The food in the reservoir K flows through apertures k in the lower part thereof to the troughs K' K', in which a float, K'', perforated at k' and inclined away from the reservoir, is placed to facilitate the feeding of the bees.

The float K'' may be made in the form of a wedge-shaped block, floating loosely in the trough K'; or a board or platform may be

hinged to the latter at the top thereof. The liquid issuing through the openings in the feed-box passes beneath the float and serves to raise the same, so as to give the bees a surface where they can gather and take their food passing through the openings in the float without becoming covered with the viscid liquid. The object of providing an inclined float having openings at or near the lower edge thereof is to permit the liquid food to be taken by the bees when the trough contains only a small quantity of food. The feeders being in place in the compartments 1 and 3, we place in the chambers 2, 4, 5, and 6 one or more honey-frames, L. We thus have four nuclei for raising queens, each nucleus having access to a feeder and all the nuclei being kept completely apart. The central chamber, 7, may be provided with honey-frames and stocked with bees, the bees having access through any one of the surrounding chambers; or it may be left unoccupied, being in this latter case used for storing necessary tools, &c.

The honey-frames we propose to employ are of the kind illustrated in Fig. 7. The cross-bar at top is constructed with a cut-away portion as shown at *l*, for purposes of ventilation and to admit the passage of bees in case, for instance, of there being honey-boxes placed above the frames. The side bars, *L'*, are connected at bottom by a section of wire, *L''*, as shown. The use of a wire instead of wood for this cross-brace has several advantages, the frame being stronger and more convenient; but the main advantage is that the wire prevents the secretion of miller and other insect eggs, enabling the bees to successfully combat these their worst enemies.

With the hive arranged as shown in Fig. 2 one or both of the partitions *J J* may be removed, leaving three or two nuclei for raising queens, each provided with a suitable feeder, and in this case the large central chamber may be used, if desired, for a large swarm for making honey, being entirely filled up with boxes or frames.

*M* represents covers, one of which may be placed over each chamber 2 4 5 6.

Now, to adapt the hive for use as a winter-hive it is arranged as shown in Fig. 3. The honey-frames and feeders are taken out of the chambers 1 2 3 4 5 6, suitable honey-frames placed in chamber 7, one or more of the bridges shown in Fig. 8 placed between gains in the bottoms of the partitions, and the entrances to the hive, as shown in Fig. 3, and the surrounding chambers 1 2 3 4 5 6 filled with chaff, sawdust, or other non conducting material. The chamber 7 is covered with duck or muslin, and the cover or hood *E* put in place. Then

the cap-piece *e* is unscrewed and all the space under the cover filled with chaff or sawdust. The cap *e* being replaced, the hive is ready for winter use, the bees having access and air through the passage-way beneath the bridge *G*. This passage way *G* allows, also, of the following arrangement of the interior of the hive for winter use, if desired: All the partitions, frames, feeders, &c., being taken out, four short partition boards, *J*, are placed in the form of a square or other figure at the inner end of said passage-way, in the center of the hive, and held together by hooks and staples and surrounded with chaff or sawdust. The bridge *G* allows free access to the hive's interior.

To run one or two large honey-making swarms in the same hive, the apparatus shown in Fig. 4 is used. A notched partition-board, *N*, is placed in the hive parallel with the sides *A*, and at a distance from the said sides to suit the size of the swarm or swarms, one of which may be run on each side of said partition.

*O O* are cross-bars, which rest in notches *a''* and *n* and support honey-frames *L*, any desired number of which may be used on each side of the partition board *N*. The spaces between the bars *O* and the sides *B B* may be filled up with honey frames or boxes, and boxes may be also placed above the frames, filling the space under the cover.

In Fig. 5 we have shown the hive divided into four compartments by one long division-board, *P*, having a notch at its middle, and two short boards, *Q*, having projections fitting in said notch.

Having thus described our invention, the following is what we claim as new therein and desire to secure by Letters Patent:

1. The combination of the long movable partitions *I*, the short partitions *I'*, arranged outside the same, and the partitions *J*, arranged transversely between the partitions *I*, with the casing or shell, substantially as and for the purpose set forth.

2. The combination of the reservoir *K*, having feed-trough *K'*, and the apertured partitions *I I'*, with the casing or shell, as and for the purpose set forth.

3. The bee-feeder consisting of the perforated reservoir *K*, trough *K'*, projecting from the lower part thereof, and the inclined perforated float *K''*, arranged in the trough *K'*, as and for the purpose set forth.

JAMES T. FIFE.  
L. E. MERCER.

Witnesses:

H. M. TOWNER,  
JOHN D. BALLANTYNE.