

(No Model.)

G. H. STOVER.  
BEE HIVE.

No. 330,353.

Patented Nov. 10, 1885.

Fig. 1.

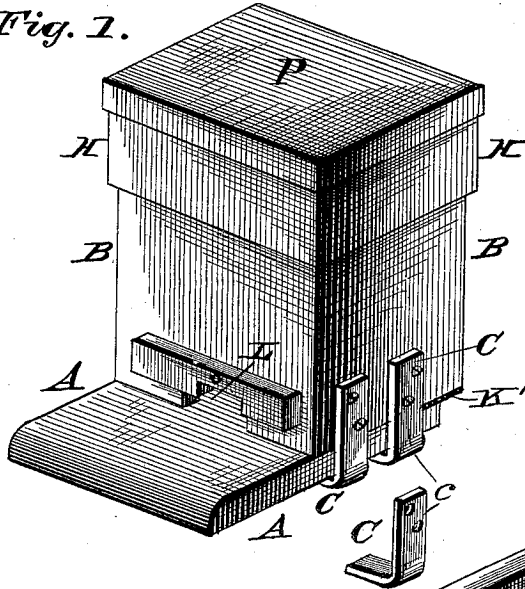

Fig. 4.

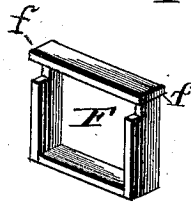

Fig. 2.

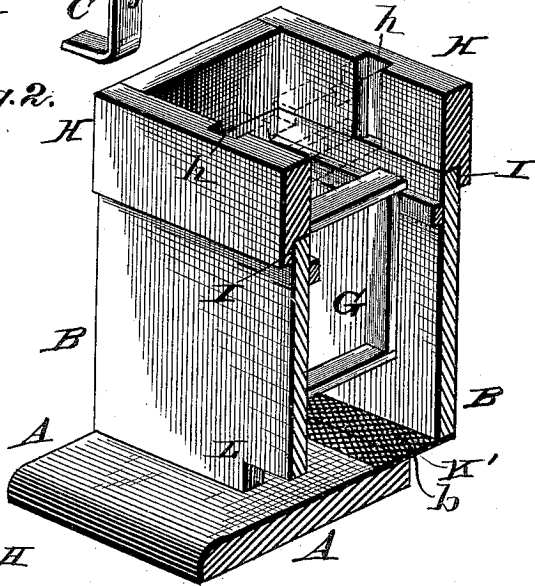

Fig. 3.

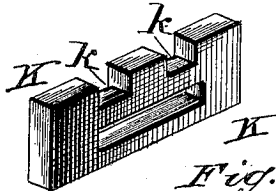
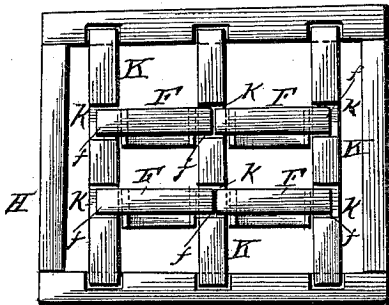

Fig. 5.



WITNESSES

*Phil C. Dietrich*  
*W. R. Keyworth*

INVENTOR  
*Geo. H. Stover*  
By *Z. S. Alexander*  
Attorney

# UNITED STATES PATENT OFFICE.

GEORGE H. STOVER, OF SOUTH BEND, INDIANA.

## (BEE-HIVE.)

SPECIFICATION forming part of Letters Patent No. 330,353, dated November 10, 1885.

Application filed January 15, 1885. Serial No. 152,939. (No model.)

### *To all whom it may concern:*

Be it known that I, GEORGE H. STOVER, of South Bend, in the county of St. Joseph and State of Indiana, have invented certain new and useful Improvements in Bee-Hives; and I do hereby declare that the following is a full, clear, and exact description thereof, reference being had to the accompanying drawings, and to the letters of reference marked thereon, which form part of this specification.

The invention relates to improvements in bee-hives, and has for its object to provide means whereby the hive may be entirely closed, or when opened for ventilation the intrusion of moths may be prevented.

The invention consists in the construction and novel arrangement of parts hereinafter described, and pointed out in the appended claims.

In the accompanying drawings, Figure 1 represents a perspective view of the hive complete. Fig. 2 shows a central vertical section of the same through the bee-entrance and with the top removed. Fig. 3 represents a perspective view of one of the removable partitions of the upper section; Fig. 4, a perspective view of one of the honey-frames of the upper section; and Fig. 5 is a plan view of the upper section of the hive, showing the partition-frames and comb-frames in place therein.

Referring to the drawings by letter, A designates the base of the hive, consisting of a flat board, which may be mounted on suitable supports.

B is the brood-chamber, of rectangular shape, and adapted to set upon the rectangular base-plate A.

C C are angle-pieces, the vertical arms *c* of which are secured to the sides of the brood-chamber, while their horizontal arms rest against the under surface of the base-plate. The said angle-pieces are preferably of cast-iron. The brood-chamber can thus be slid back and forth on its base, so that it may be either perfectly closed below or a space, *b*, may be left between its rear edge and the rear edge of the base for ventilating purposes.

K' is a sheet of wire-gauze or perforated metal, which has its rear edge secured to the rear edge of the brood-chamber, and lies upon the upper surface of the base-plate. The sheet K' is made sufficiently wide to cover the space

*b*. However, the latter may vary in width within desirable limits. Thus the ventilating-space *b* is never unclosed for the intrusion of moths.

The brood-chamber is provided with the usual frame, G, suspended therein in any suitable manner.

H is the upper section of the hive, rectangular in form, and rabbeted around the interior of its lower edge, I, to fit upon the upper edge of the lower section, as shown. The front and rear sides of the upper section are provided on their interior surface with opposite vertical grooves *h* for the accommodation of the side edges of the removable partitions K, which divide the interior of the upper sections into compartments in which the comb-frames F are hung.

*h h* are notches in the upper edges of the partitions K, which engage the upper extended ends, *f*, of the comb-frame F, and suspend the latter between the partitions.

L is the entrance to the hive, and P is a cover, which fits down over the upper section.

When it is desired to ventilate the hive, the same is moved back upon the base-plate A, so that the rear edge of the former stands clear of the latter, the wire-gauze offering an effectual barrier to the entrance of moths. To close the hive, the body is drawn back on the bed-plate.

Having thus described my invention, what I claim is—

1. The base-plate A, in combination with the chamber B, having the wire-gauze K' secured to its rear edge and lying upon the upper surface of the base-plate, and the angle-pieces C, secured to the outer surface of the chamber B, substantially as specified.

2. The combination of the base-plate A, lower section, B, having the wire-gauze K' attached, and the angle-pieces C, with the upper section, H, partition-frames K, and comb-frames F, substantially as specified.

In testimony that I claim the foregoing as my own I affix my signature in presence of two witnesses.

GEORGE H. STOVER.

Witnesses:

JAMES DU SHANE,  
CHAS. W. WILEY.