

(No Model.)

J. LASER.

BEE HIVE.

No. 383,737.

Patented May 29, 1888.

Fig. 1

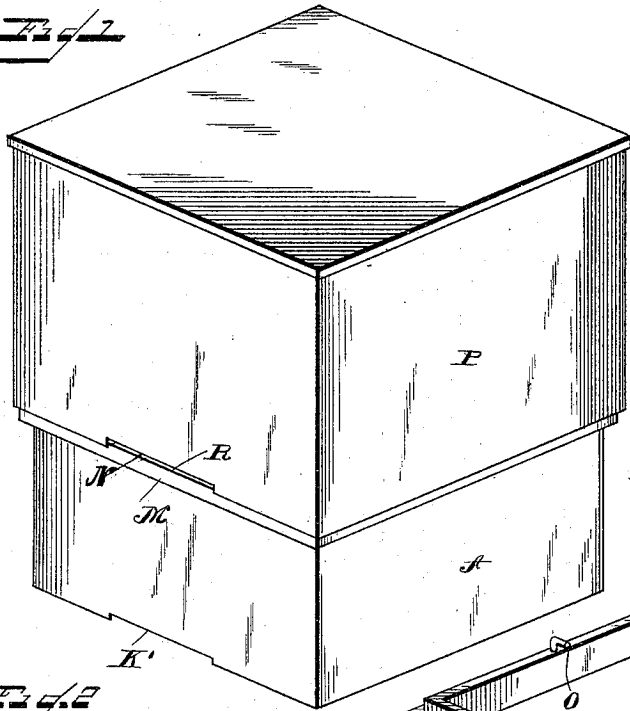

Fig. 5

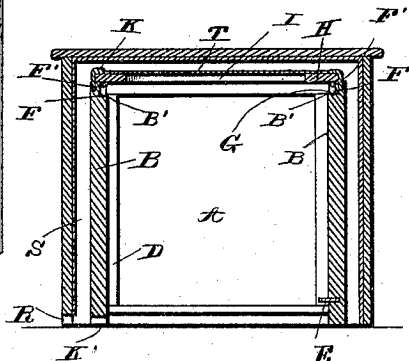

Fig. 4

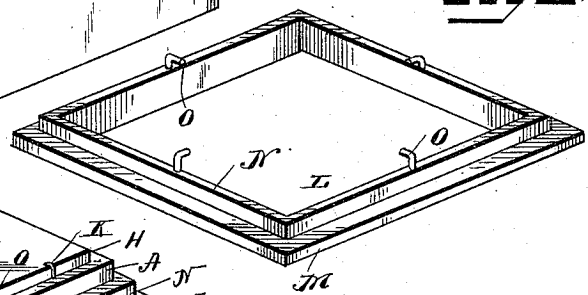

Fig. 3

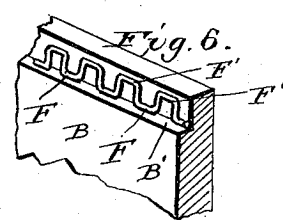
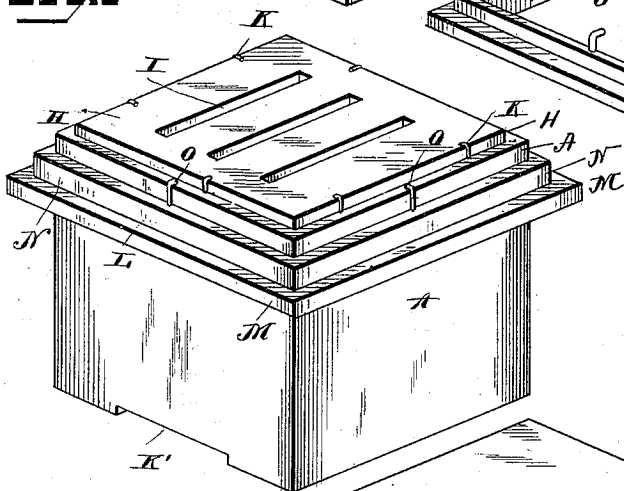
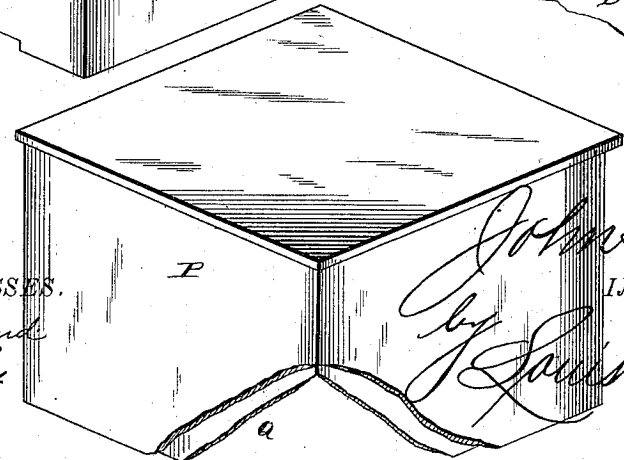

Fig. 7



WITNESSES.

F. L. Curran
J. F. Reily

John Laser,
 INVENTOR.
By J. Louis Rogers & Co.
 Attorneys.

UNITED STATES PATENT OFFICE.

JOHN LASER, OF BREMEN, INDIANA.

BEE-HIVE.

SPECIFICATION forming part of Letters Patent No. 383,737, dated May 29, 1888.

Application filed December 27, 1887. Serial No. 259,194. (No model.)

To all whom it may concern:

Be it known that I, JOHN LASER, a citizen of the United States, and a resident of Bremen, in the county of Marshall and State of Indiana, have invented certain new and useful Improvements in Bee-Hives; and I do hereby declare that the following is a full, clear, and exact description of the invention, which will enable others skilled in the art to which it appertains to make and use the same, reference being had to the accompanying drawings, which form a part of this specification, and in which—

Figure 1 is a perspective view of my improved bee-hive, showing the same arranged for summer. Fig. 2 is a perspective view showing the outer casing removed. Fig. 3 is a detail view of the said casing, partly in section. Fig. 4 is a detail view of the supporting-ring. Fig. 5 is a central vertical sectional view showing the hive arranged for winter, and Fig. 6 is a detail perspective view of a portion of one side of the hive.

The same letters of reference indicate corresponding parts in all the figures.

My invention consists in certain new and useful improvements in bee-hives, which will be hereinafter fully described and claimed.

Referring to the several parts by letter, A indicates the square frame of a bee-hive, or the hive proper. The upper inner edges of two sides, B B, of this casing A are recessed longitudinally to form the shoulders B' B', which support the projecting ends of the ordinary removable frames, D. The lower ends of these frames are held apart by means of the projecting pins E, which project in from one of the sides B, near the lower end of the same, while the upper ends of the frames are held separate upon the shoulders B' B' by the metal frames F F. These metal frames consist each of a single wire, which is crimped or bent to form a series of upwardly-projecting loops, F', and a straight length of wire between each two loops, and these wire frames are secured upon the shoulders B' B', as shown in the drawings, so that as the frames D are placed in position the projecting ends of their top piece will fit and rest between the said loops, resting upon the straight portions of the wires. The wire frames are secured in position upon the shoulders B' by small staples G G, or in any other suitable manner.

The upper end of the hive A is closed by the removable top board, H, which is formed with the slots I, and which is held removably in position on the top of the hive by the turn-hooks K. The usual opening or door, K', is formed at the bottom of one side of the hive A, through which the bees enter the hive.

L indicates a supporting collar or frame, which is of such a size that it will fit loosely around the hive A, and this square frame or collar is formed with the exterior shoulder, M, forming the upwardly-projecting flange N above the said shoulder. This collar is placed in position on the hive in summer by sliding it down over the top of the hive, when it is held in position around the upper end of the hive by the supporting-hooks O, which are secured in the top of the flange of the collar, so that their hooked ends will fit over the upper edge of the hive A, as shown clearly in Fig. 2 of the drawings.

P indicates the outer casing, which consists of a square box which is larger and deeper than the hive A, to which it is adapted, and which is open only at its lower end. This box is usually formed of close-grained wood, and is then thoroughly lined with one or more layers of paper, Q, as many layers of paper being employed as are necessary to make the casing a non-conductor of cold and heat. The wooden casing has its entire inner surface closely lined with paper to prevent the cold from penetrating at any point. The bottom of one side of this casing has a small opening or entrance, R, formed in it, which, when the casing is placed entirely over the hive in winter, registers with the entrance K' in the bottom of the hive.

In summer several small extra boxes are placed upon the top of the hive A over the holes or slots I in the top board, H, in the usual manner, and the supporting ring or, rather, collar L is placed in position, as shown in the drawings, with the hooks O supporting it around the upper end of the hive. The paper-lined casing P is then placed in position over the top of the hive, as shown in Fig. 1, covering the top thereof and the extra boxes which may be resting upon the top, the lower edges of this casing resting upon the shoulder M, which extends around this collar, while the flange N of the collar extends up within the

lower end of the casing and closes the bottom opening, R, of the casing. It will be seen that when the non-conducting casing is thus arranged over the top of the hive in summer it will, while increasing the size of the hive and its capacity, thoroughly protect the honey-boxes from the sun and heat.

In winter the extra honey-boxes (which are not needed in winter) are removed, and the supporting-collar is also removed. The casing P is then placed down over the entire hive A, with the entrance R in its bottom registering with the entrance K' in the bottom of the hive. This paper-lined non-conducting casing is sufficiently larger than the hive over which it fits to leave an air-space, S, all around the hive when placed down over the hive in winter; and it will thus be seen that this non-conducting casing, while thoroughly protecting the hive and bees from the intense cold in winter, as the cold cannot penetrate through the non-conducting walls of the casing, will permit the fresh air to circulate, passing in through the hole at the bottom of the paper-lined casing, up through the space between the said casing and the hive, and down through the slots in the top of the hive to the bees, while all bad air can escape out through the door at the bottom of the hive. The body of air between the non-conducting casing and the hive, which extends completely around the sides and top of the hive, will also act as a non-conductor and prevent the cold from penetrating into the hive.

In order to prevent the bees from escaping out through the openings in the top of the hive in winter, I lay a screen, T, of ordinary construction, over the top of the hive, which, while affording free passage to the pure air down into the hive, will at the same time prevent the bees from coming up through the top slots.

From the foregoing description, taken in connection with the accompanying drawings, the construction and advantages of my invention will be readily understood. It will be seen that the paper-lined non-conducting outer casing will effectually protect the bees from cold in the winter, and will also, when supported on the removable collar, protect the honey-boxes from sun and heat.

Having thus described my invention, what I claim, and desire to secure by Letters Patent of the United States, is—

The combination, with a bee-hive, of the supporting-collar formed with the exterior shoulder and having the supporting-hooks, and the cover or casing lined with a non-conducting material and formed at its bottom with a small opening or entrance, as set forth.

In testimony that I claim the foregoing as my own I have hereunto affixed my signature in presence of two witnesses.

JOHN LASER.

Witnesses:

B. H. BOWMAN,
THURLOW B. PHILLIPS.