

N. D. WEST.  
QUEEN CELL PROTECTOR AND QUEEN CAGE.

No. 465,010.

Patented Dec. 15, 1891.

Fig. 1.

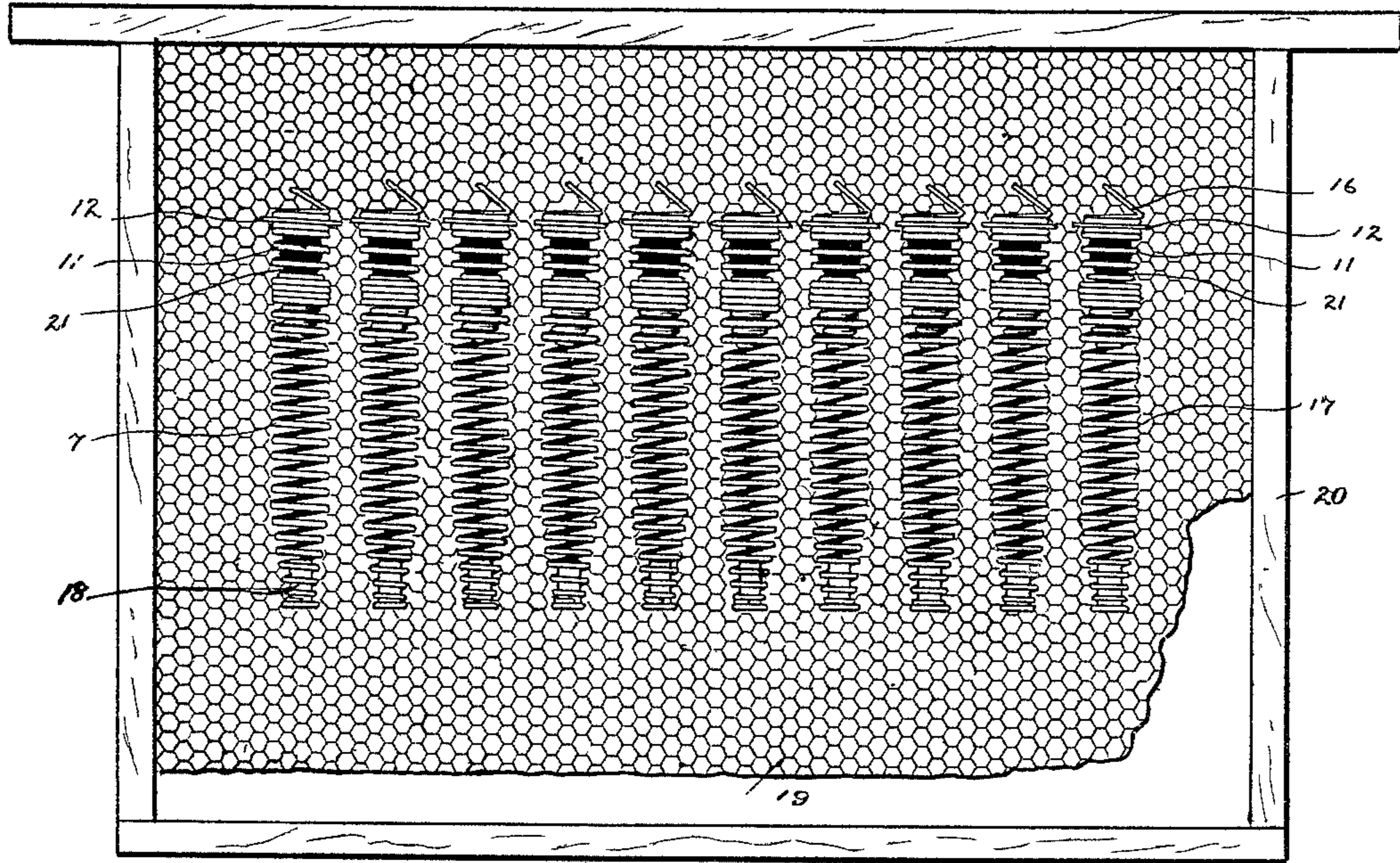
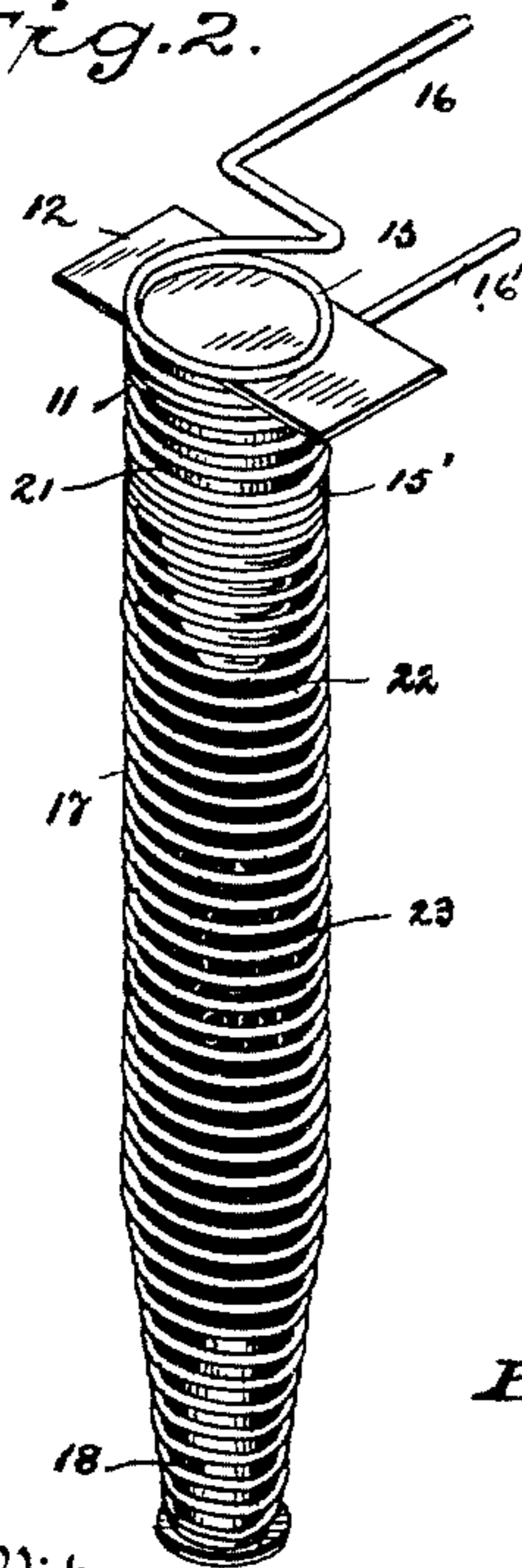

Fig. 2.



Witnesses

H. A. Lamb

Geo W. Whitney

Fig. 3.

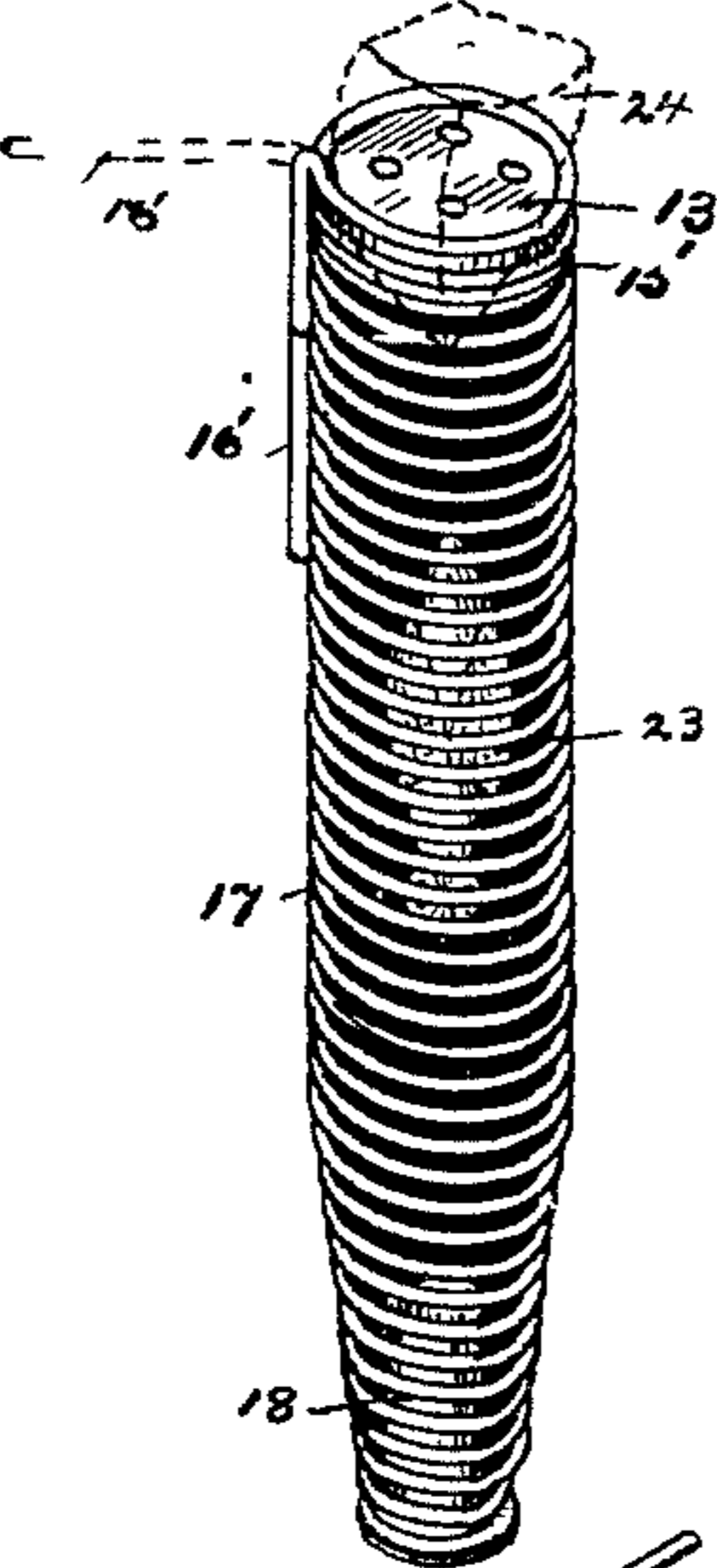

Fig. 4.

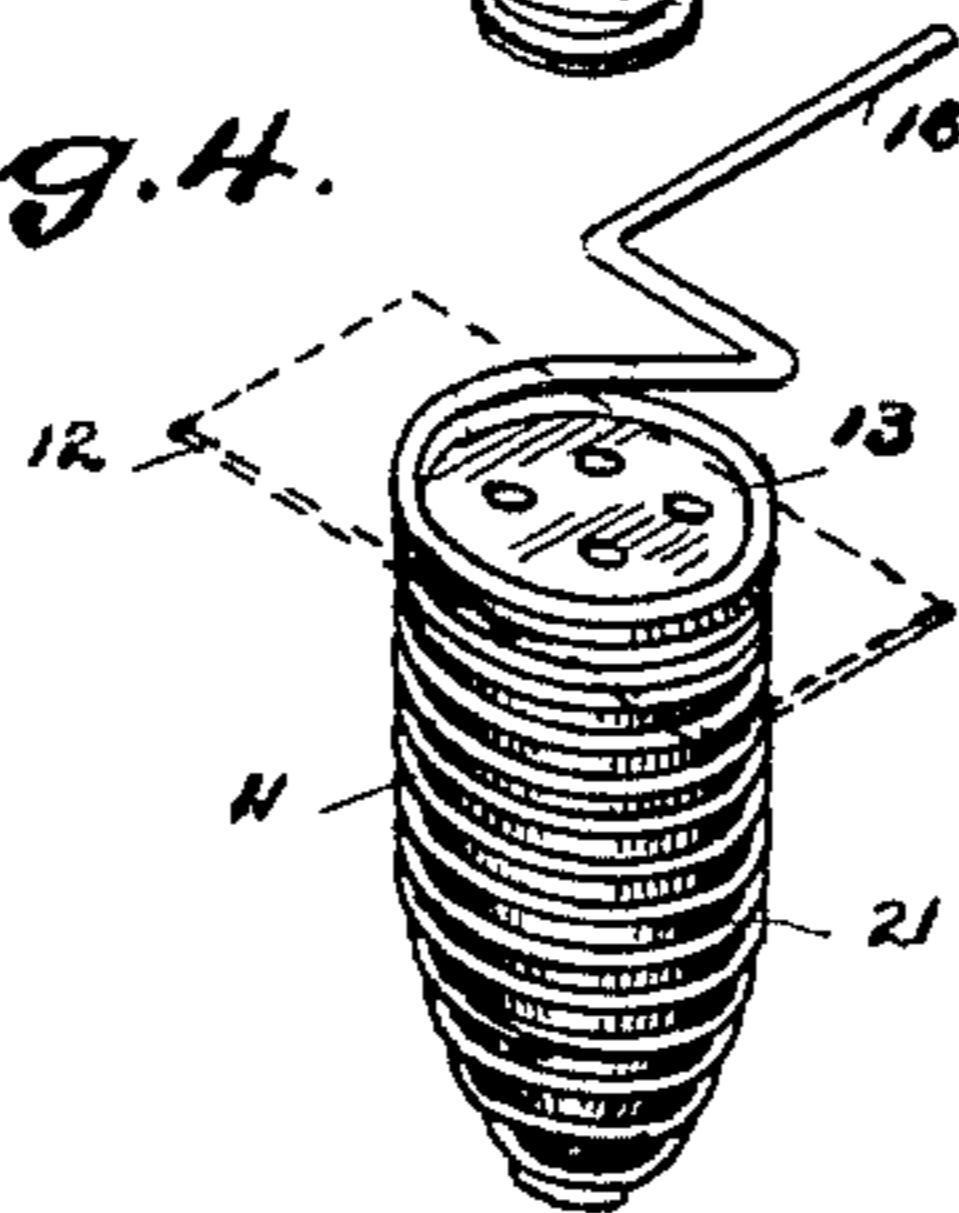
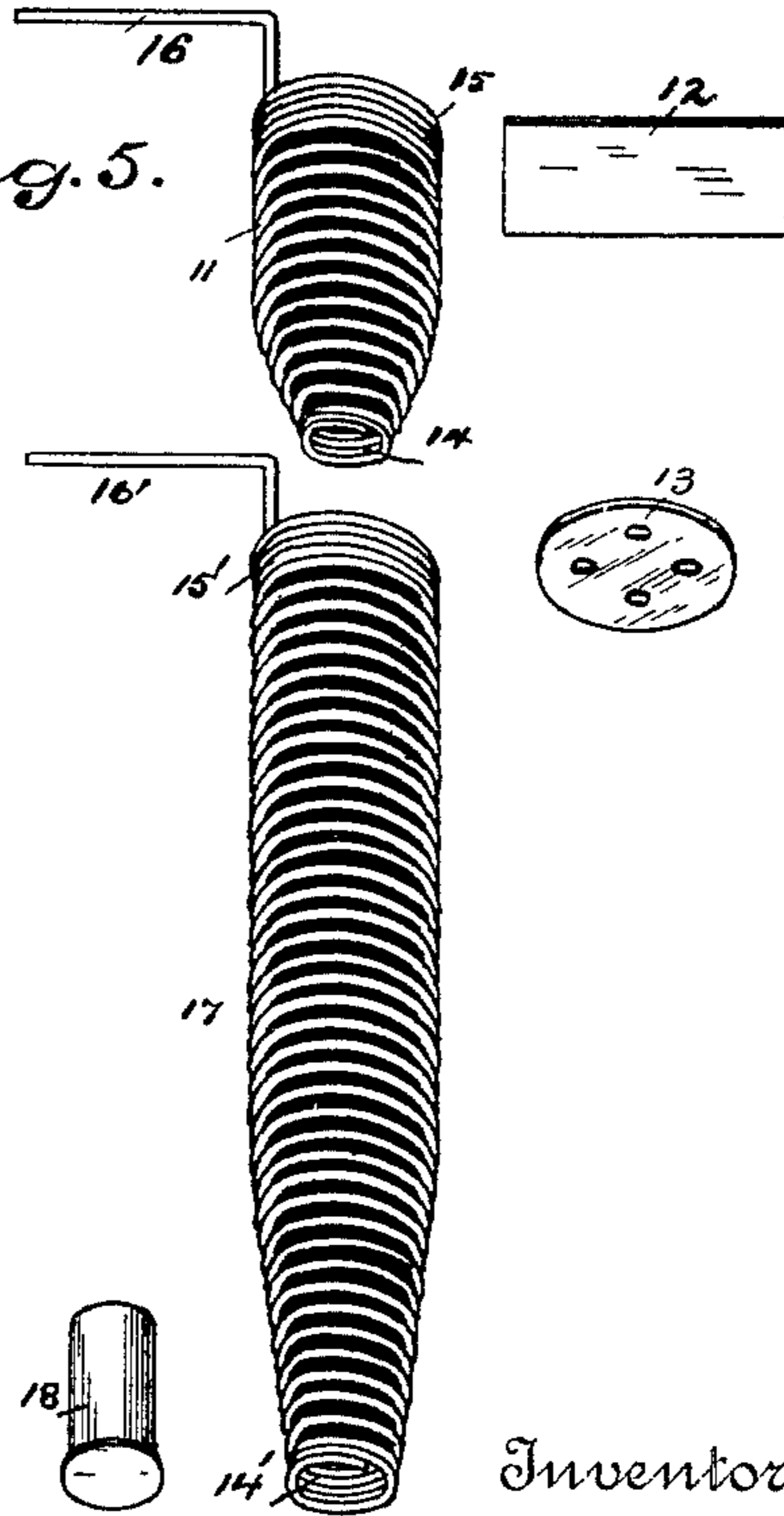

Fig. 5.



Inventor

NOAH D. WEST

by

*[Signature]*

Attorney

N. D. WEST.  
QUEEN CELL PROTECTOR AND QUEEN CAGE.

No. 465,010.

Patented Dec. 15, 1891.

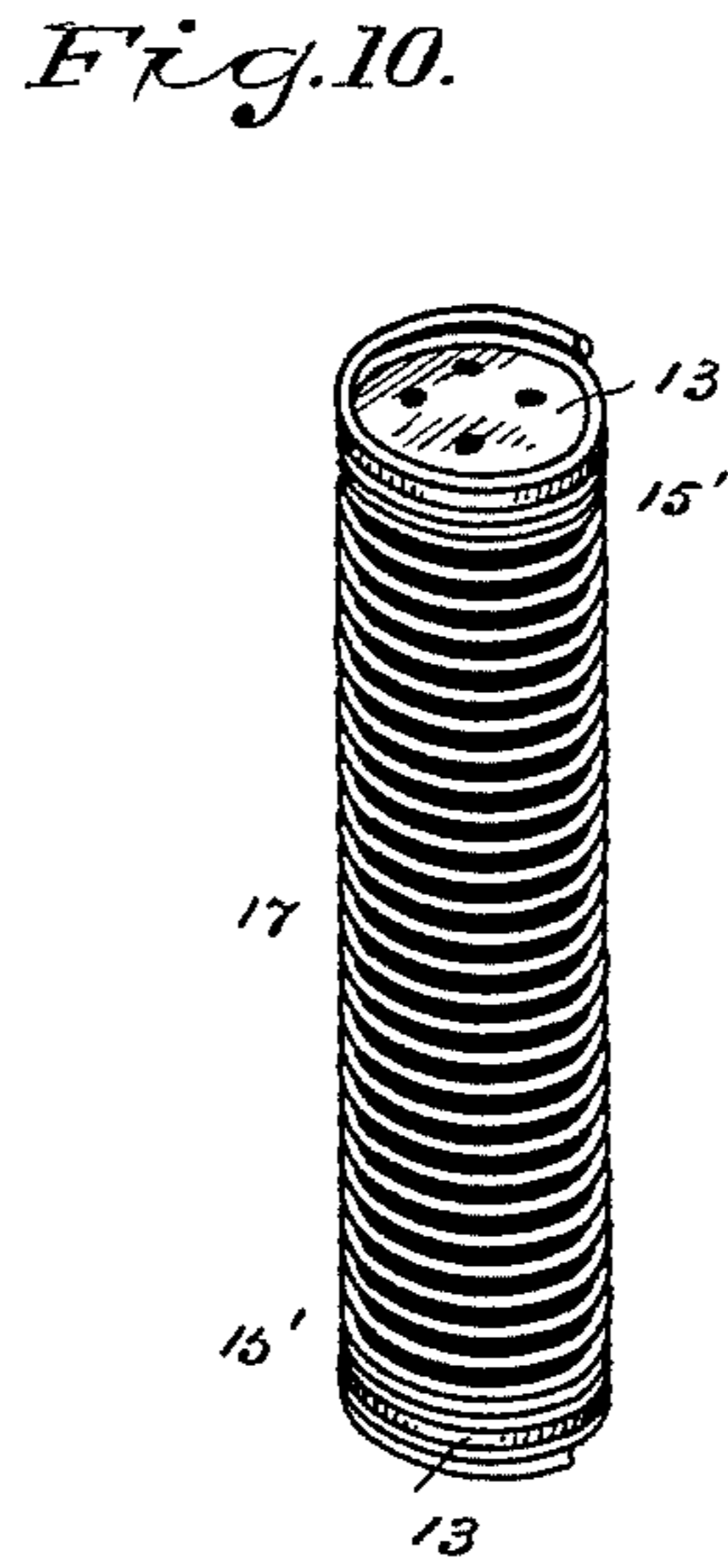
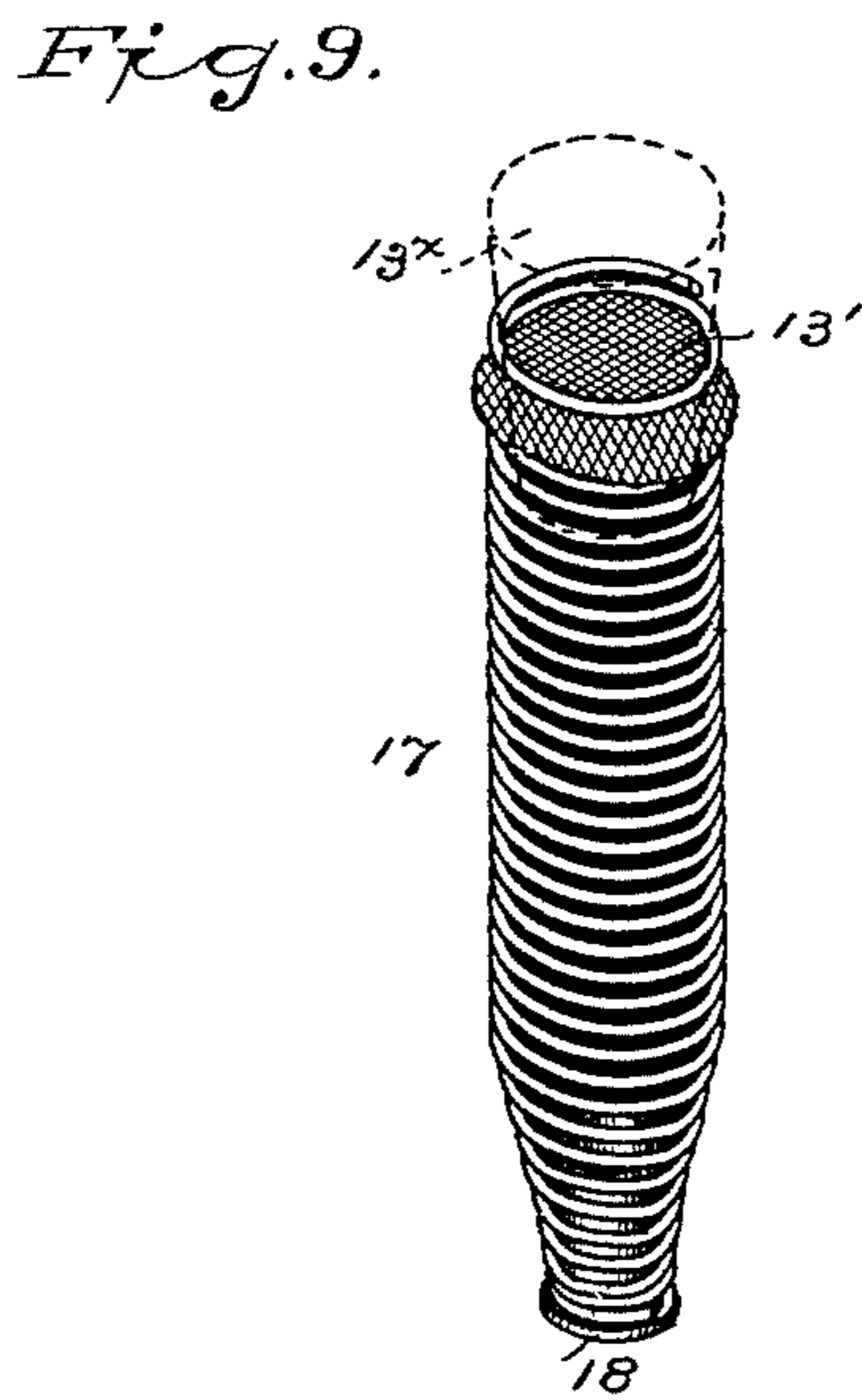
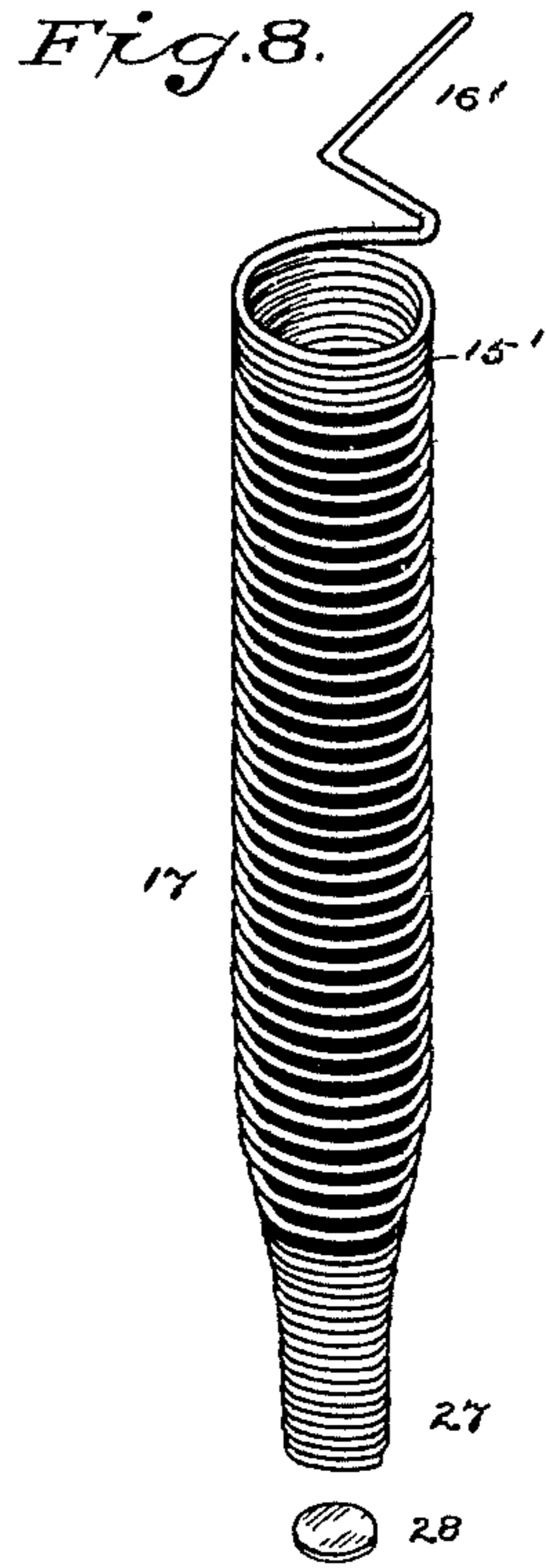
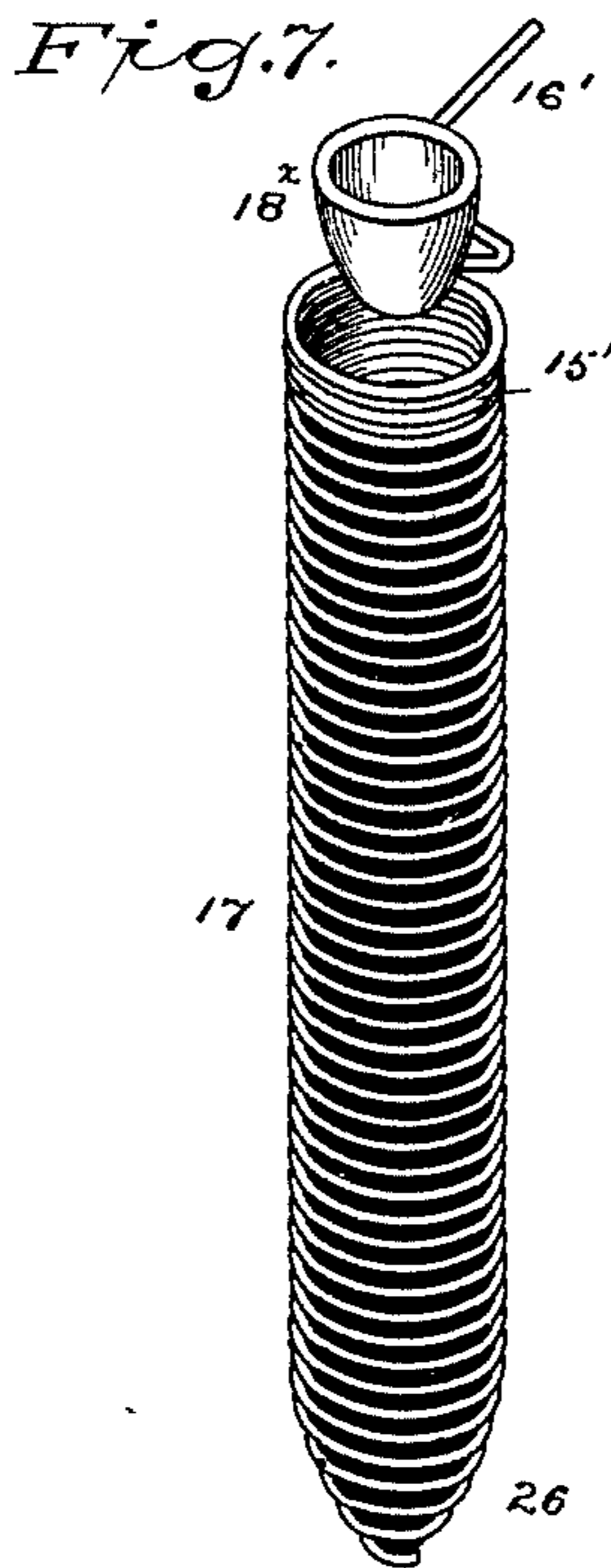
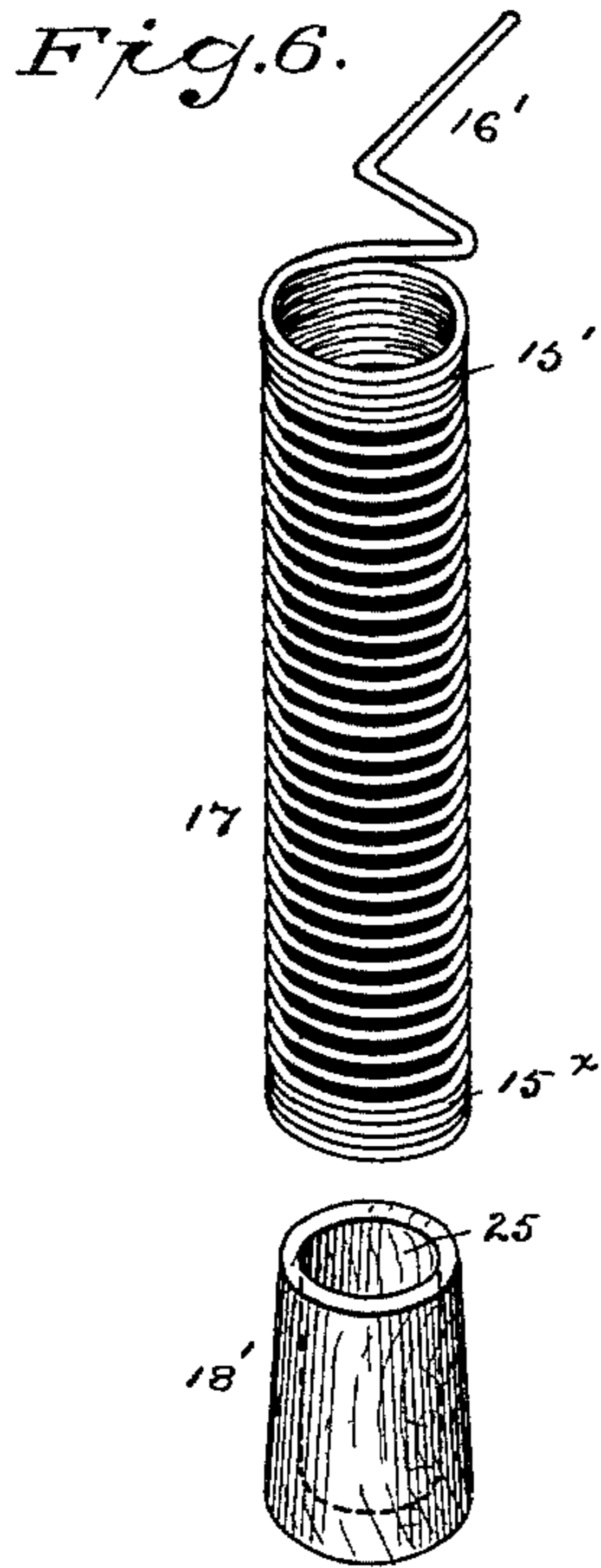

Witnesses  
*H. A. Lundy*  
*Geo W. Whitney.*

Inventor  
 NOAH D. WEST  
 by *[Signature]*  
 Attorney

# UNITED STATES PATENT OFFICE.

NOAH D. WEST, OF MIDDLEBURG, NEW YORK.

## QUEEN-CELL PROTECTOR AND QUEEN-CAGE.

SPECIFICATION forming part of Letters Patent No. 465,010, dated December 15, 1891.

Application filed April 27, 1891 Serial No. 390,696. (No model.)

*To all whom it may concern:*

Be it known that I, NOAH D. WEST, a citizen of the United States of America, and a resident of Middleburg, Schoharie county, in the State of New York, have invented a new and useful Improvement in Queen-Cell Protectors and Queen-Cages, of which the following is a specification.

This invention relates to accessories for bee hives; and it consists in an improved queen-cell protector and a novel queen-cage, both composed mainly of wire in spiral coils, hereinafter termed "spiral wire," and adapted to be used together or in combination with each other and also singly or separately, as hereinafter set forth.

The general objects of the invention are, first, to protect individual queen cells and young queens against being destroyed by bees in such a way as to provide for forming a safe and effective queen-nursery in any hive; secondly, to facilitate handling, carrying, shipping, and introducing queen bees, and especially the introduction of substitute queen-cells or new queens into hives with safety, and, finally, to discourage or prevent the swarming of bees and to facilitate the introduction of swarms into new hives.

Two sheets of drawings accompany this specification as part thereof.

Figure 1 of the drawings is an elevation of a queen nursery as formed in a bee-hive by means of my improved cell-protectors and cages. Fig. 2 is a perspective view of a protector and a cage as combined with each other in the nursery. Fig. 3 is a like view of the cage detached, showing it in full lines as used for carrying and shipping queens and, with the aid of dotted lines, as used for introducing the queens into hives. Fig. 4 is a like view of the protector detached, showing it as used with the same or a different cover for introducing queen cells into hives. Fig. 5 is a perspective view of the several parts of the protector and cage separated; and Figs. 6 to 10, inclusive, are perspective views of other queen-cages constructed according to the same invention in part, and illustrating various modifications, as hereinafter described.

Like reference-numbers indicate corresponding parts in the several figures.

The improved queen-cell protector (shown

in Figs. 1, 2, 4, and 5) is composed of a conoidal spiral wire body 11 and a suitable cover 12 or 13. The body 11 is of a sufficient length to admit a queen cell within it and is approximately of the same shape as the cell. Its small end has a permanently open outlet 14, Fig. 5, large enough for a queen to pass through easily. Its upper end has two or more closely wound coils 15, between two of which the cover 12 or 13 is held in place by the elasticity of the wire, and the upper extremity of the wire forms a spur 16, adapted to be thrust into honey comb, as in Fig. 1, to attach the protector to the side of the comb, so as to cause it to hang vertically and support the cell in its natural position. The cover 12 is an oblong piece of tin, thick paper, thin wood, or the like, tin being preferred, and this form is preferred for the protector. The cover 13 (shown in full lines in Fig. 4 as applied to a protector) is a flat perforated button of suitable size and preferably of metal, its holes serving as air-holes.

The queen cage comprises a spiral wire body 17 of about the same diameter at its upper end as the cell-protector 11, and of sufficient length to accommodate within it a full-grown queen, together with a few workers, if it is to be used for shipping purposes. Three or four inches is considered sufficient.

In the preferred species represented by Figs. 1 to 5, inclusive, the cage body 17 is substantially identical with the protector body 11, except as to length. This facilitates manufacture and has given satisfaction in practice. The spur 16' and close coils 15' at the upper end of the cage body are for the same purposes as those of the protector-body. The opening 14' in its lower end is tightly fitted with a feeder 18, which may consist, as represented, of the empty copper-shell of a cartridge of suitable caliber. The button-cover 13 is preferred for the cage, as indicated in Fig. 3; but either cover above described or a cover of any preferred kind may be used successively on the protector and then on the cage.

In the nursery, Fig. 1, a number of cell-protectors (shown at 11 11) and queen-cages 17 17, united, as in Fig. 2, by screwing or pressing the lower end of each protector into the upper end of a cage, are supported by

their spurs 16 16' on one side of the honey comb 19 within a comb frame 20, and the spurs and comb in this combination prevent any accidental separation of the cages from the protectors. In producing or preparing such a nursery I proceed as follows: Five or six days after a hive of choice bees has cast its first swarm of the season I open the hive and lift out the frames of honey-comb containing the queen cells. With care not to jar the cells I cut out each unhatched queen cell 21 by means of a warmed penknife-blade, and keeping them right-end up all the while I place them successively in cell-protectors, then apply the covers 12, (or 13,) and then insert the lower end of each cell-protector in the spur end of a queen cage the feeder 18 of which has been supplied with some honey. When all the available cells have thus been inclosed, I hold the comb frame 20 in perpendicular position with one hand and with the other hand take the united queen-cell protectors and cages, Fig. 2, and hang them all on one side of the comb 19 by pushing their spurs 16 16' through the comb. I then place all the combs back in the hive with the nursery-comb, Fig. 1, in the middle. The queen-cells are now completely protected against destruction by the bees or by rival queens, and when a cell hatches the young queen, eating her way out at 22, Fig. 2, runs down through the outlet 14 of the cell-protector into the cage beneath, as represented in dotted lines at 23, Fig. 2, and is supplied with honey by the feeder 18. After all the cells have hatched, the nursery-comb may be removed from the hive, and the queens, already caged, are ready for immediate transfer to other hives or for shipment.

If a queen is to be carried in the pocket a short distance, it is only necessary to separate the cage from the protector, to apply a cover 13 or 12 to the cage, and to bend down the cage-spur 16', as represented in full lines in Fig. 3. If it is to be shipped by mail, a few workers from the same hive are inclosed therewith, and the cage is rolled up in a descriptive circular with a suitable wrapper, leaving its ends or its perforated cover 13 exposed for the admission of air. To introduce a queen so obtained or any other queen thus caged into a hive, I close the spur end of the cage with a piece of comb honey 24 and attach the cage to a central comb within the hive by means of its spur 16', as represented by dotted lines in Fig. 3. By the time the comb honey 24 is eaten the bees have become acquainted with the queen and are ready to welcome her when she leaves the cage.

Instead of placing the cells back into the same hive, as above, I sometimes proceed thus: (See Fig. 4.) After inclosing each cell in a protector and applying its cover 12 or 13 I go to as many hives as I have queen cells, kill the old queen in each hive, hang a protector inclosed cell on the upper part of a comb by pushing the spur 16 of the cell-protector

through the comb, and then close the hive. Owing to the protector and its cover, the bees cannot destroy the cell, as they never attack the lower end of a cell, and this is the only part exposed. The queen will hatch out in two or three days, and run down on the comb, and in about eight days more will begin to lay. I prefer this way of re-queening a yard of bees, especially in the swarming season. The objects are to re-queen cheaply with the best queens and to discourage swarming.

So far as I have discovered, hives provided with new queens from the cell in the swarming season, as above, do not swarm that season, but produce box honey in large quantities, and the swarms are in the best condition for winter. The young queens will rear young bees late in the season, and they are the ones that best stand the long winters of the north.

In order to introduce swarms into new hives, having clipped the wings of the queens, so that when a hive casts a swarm the queen cannot fly away, but remains in front of the hive, I pick up such a queen and fasten her in one of my queen cages by means of its cover 12 or 13. I then remove the parent hive to a different stand and place a new hive where the former stood, with the caged queen partly within the entrance of the new hive. All this is done while the swarm is flying around in the air. Finally the bees return to their old location in search of the queen, and when she is liberated will follow her into the new hive.

An otherwise suitable parent hive from which a swarm has just issued as above preferably furnishes the cells and the location for the queen nursery, Fig. 1, above described.

The modified queen-cage represented by Fig. 6 has a cylindrical spiral-wire body 17, having the above-described attaching-spur 16' and cover-holding close coils 15' at its upper end and similar close coils 15' at its lower end, to which I fit a feeder 18' in the form of a wooden stopper, having a suitable cavity 25.

The modified queen-cage represented by Fig. 7 has a spiral-wire body 17, closed at bottom by a cup shaped coil 26, the upper end of the body 17 having an attaching spur 16' and cover-holding close coils 15', as before. This style of cage is designed to receive loosely within it a feeder-cup 18', of glass or any other suitable material, or it may be a metallic cartridge shell.

The modified queen-cage represented by Fig. 8 has a spiral wire body 17, provided at its upper end with an attaching spur 16' and cover holding close coils 15', as above, and its lower end has a contracted and closely-coiled extremity 27, provided with a bottom 28, of sheet metal or the like, to form a feeder integral with the body of the cage.

The modified queen-cage represented by Fig. 9 may be identical with the one first described, as represented on Sheet 1 of the drawings, except that the attaching-spur and close coils are omitted, and it is covered with a pliable sheet 13', of wire-gauze, for shipping pur-

poses. The alternative stopper-shaped cover represented in dotted lines at 13<sup>x</sup>, Fig. 9, may be of wood or cork and is suitable for use when close coils are omitted. A sufficiently thick cover of the pattern represented at 12, Figs. 1 to 5, may also be used without close coils.

The modified queen-cage represented by Fig. 10 has a cylindrical spiral wire body without an attaching-spur and with cover-holding close coils 15' at both ends, which may preferably be fitted with button covers 13 for shipping purposes. Said pliable cover 13' may obviously be made of thin sheet metal with or without perforations, and may be used on any of the spiral-wire queen cages for shipping purposes, and other like modifications will suggest themselves to those skilled in the arts of keeping bees and making wire fabrics.

In the described combinations illustrated by Figs. 1 to 4 the honey-comb serves as a mechanical or structural support for the queen-cell protectors and queen-cages, either or both, and co acts with both, as in Figs. 1 and 2, to securely unite them, as well as to support them in effective position for protecting and caging the young queens as they are hatched. One of the protectors and one of the cages may obviously be combined with each other and with a honey-comb in like manner.

Having thus described the said improvement, I claim as my invention and desire to patent under this specification—

1. The combination, in a queen-nursery, of one or more vertically-arranged queen-cell protectors and one or more subjacent queen cages in communication with such protectors, each protector being provided at its upper end with a suitable cover and having at its lower end an orifice through which the queen may issue into the subjacent cage when the cell within the protector is hatched, substantially as hereinbefore specified.

2. The combination, in a queen nursery, of a vertically arranged queen cell protector and a subjacent queen cage communicating with each other at the lower end of the protector and both having bodies of spiral wire with attaching spurs formed by the upper extremities of the wire of both and adapted to be thrust into or through a honey comb to unite and support them, substantially as hereinbefore specified.

3. The combination, with a suitable cover, of a queen-cell-protector body of spiral wire,

having an attaching-spur and cover-holding close coils at its upper end and a contracted lower end provided with a queen-outlet, and a queen-cage having a spiral-wire body, the upper end of which incloses said lower end of the protector and has like close coils to receive the same or a different cover after the protector is detached, substantially as hereinbefore specified.

4. A queen-cell protector composed of a spiral-wire body having an attaching spur at its upper end and a contracted queen outlet at its lower end and a suitable cover applied to its upper end, substantially as hereinbefore specified.

5. A queen-cell protector composed of a spiral wire body having an attaching-spur and cover-holding close coils at its upper end and a contracted queen-outlet at its lower end, and a suitable cover held between said close coils by the elasticity of the wire, substantially as hereinbefore specified.

6. A queen-cage constructed with a spiral-wire body having an attaching-spur at its upper end, substantially as hereinbefore specified.

7. A queen-cage constructed with a spiral-wire body having cover holding close coils at its upper end, substantially as hereinbefore specified.

8. A queen cage having a spiral wire body provided at its lower end with a cup shaped queen feeder closing said lower end of the body, substantially as hereinbefore specified.

9. A queen-cage body composed of spiral wire with a tapering lower end, which is provided with a feeder in the form of a flanged cup tightly fitted into the extremity of said lower end, substantially as hereinbefore specified.

10. The combination, with a suitable cover, of queen cell protector and queen-cage bodies of spiral wire of one and the same pattern, except as to length, the protector-body being closed at top by said cover and having a tapering lower end provided with a queen-outlet, and the longer queen-cage body having its upper end filled by said lower end of the protector-body and having its contracted lower end provided with a queen-feeder, substantially as hereinbefore specified.

N. D. WEST.

Witnesses:

W. E. BASSLER,  
GEO. PETENTLE.