

(No Model.)

2 Sheets—Sheet 1.

W. O. LEACH.  
PRESS FOR HONEY SECTIONS.

No. 470,893.

Patented Mar. 15, 1892.

Fig. 1

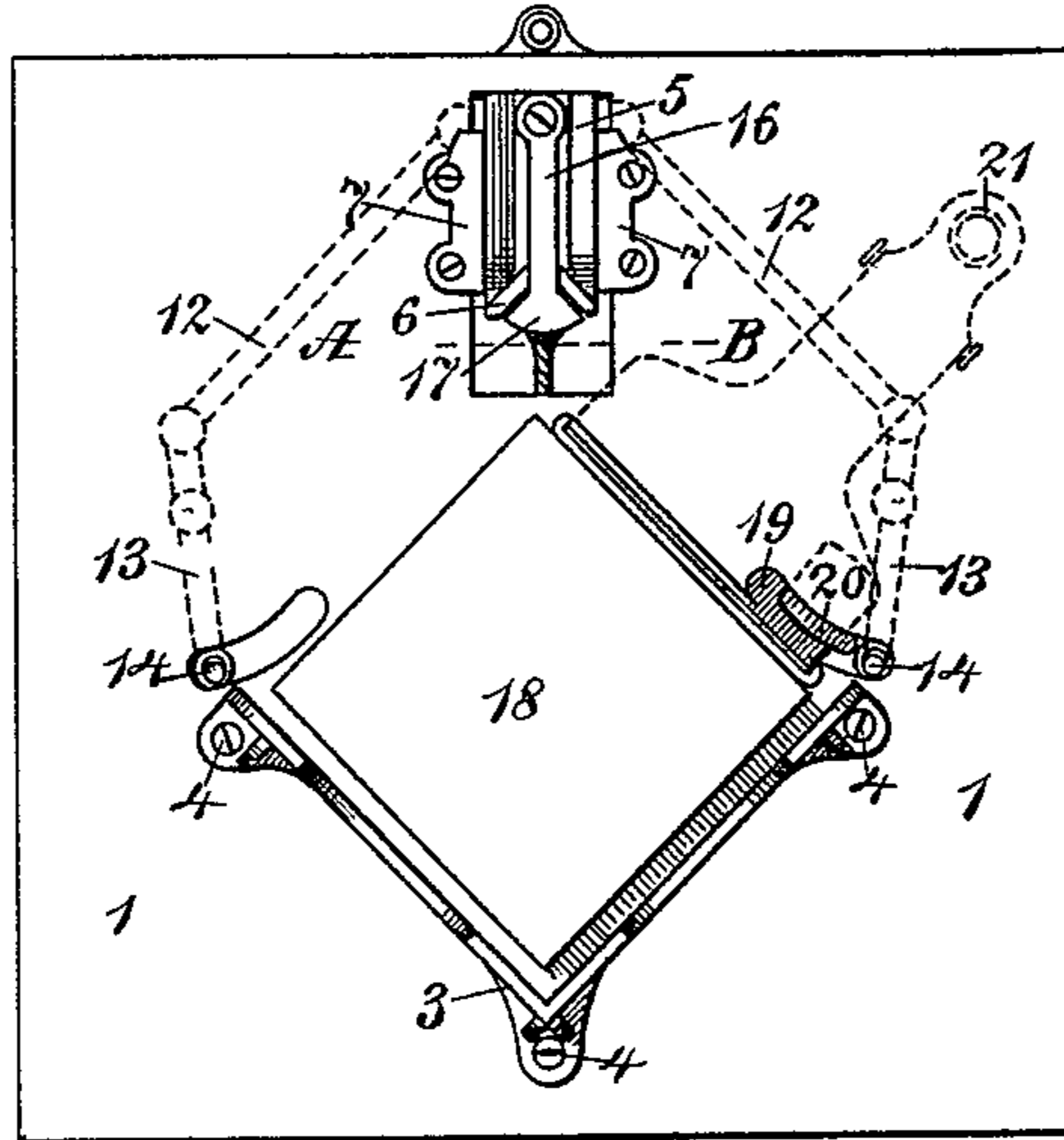
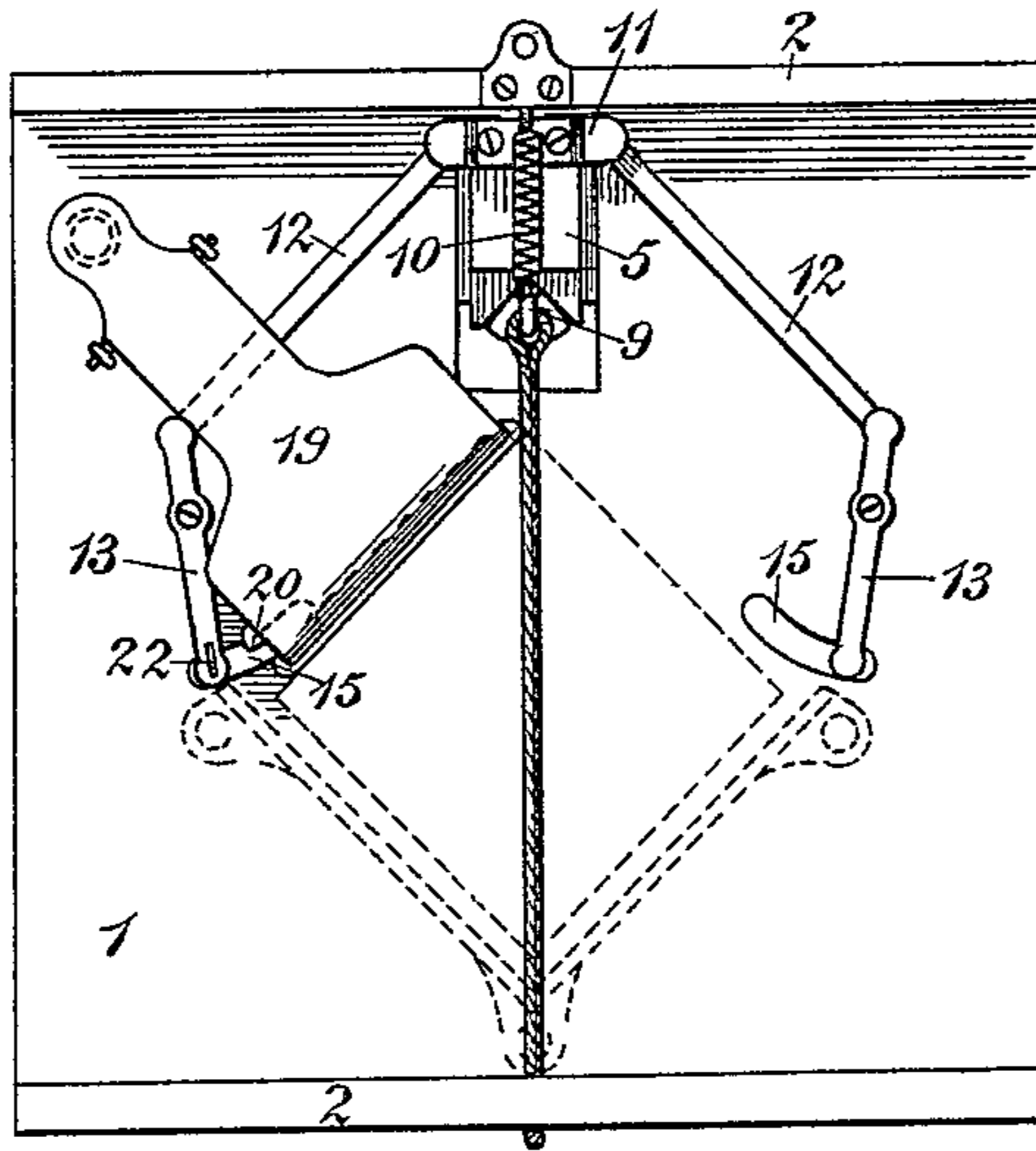

Fig. 2



Witnesses.

Charles Priestman  
John Rowlett

Inventor

Walter O. Leach

Per W. J. Graham  
Atty

W. O. LEACH.  
PRESS FOR HONEY SECTIONS.

No. 470,893.

Patented Mar. 15, 1892.

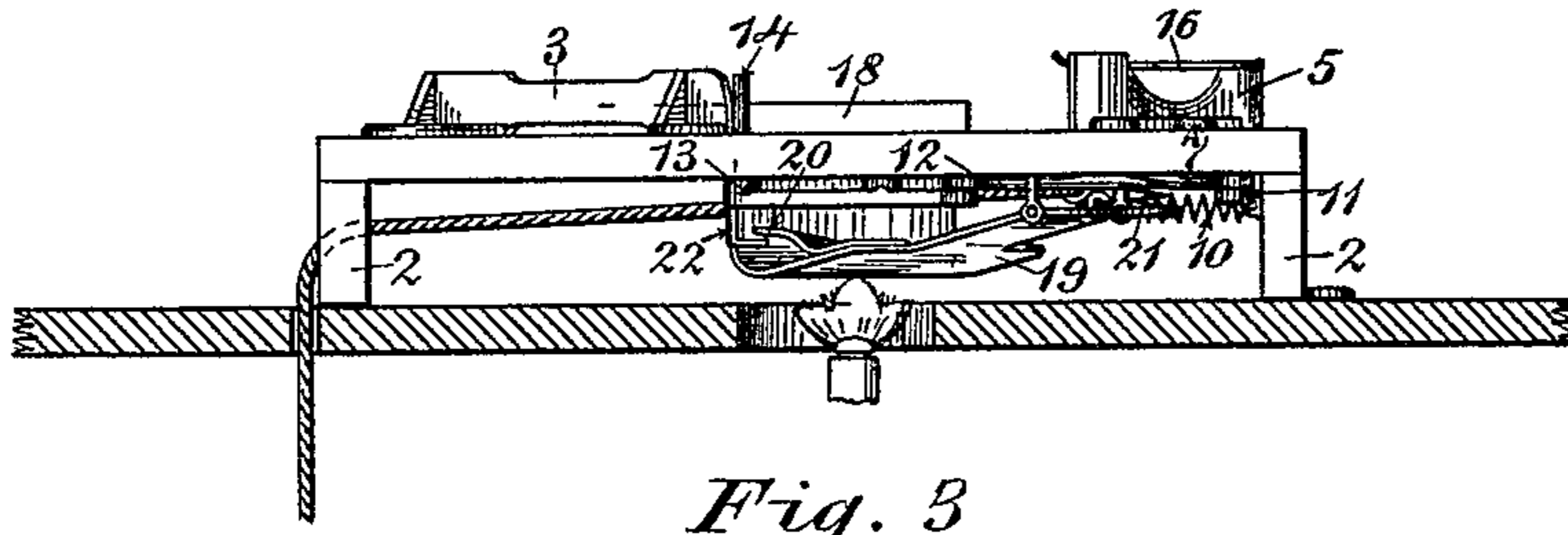

Fig. 3

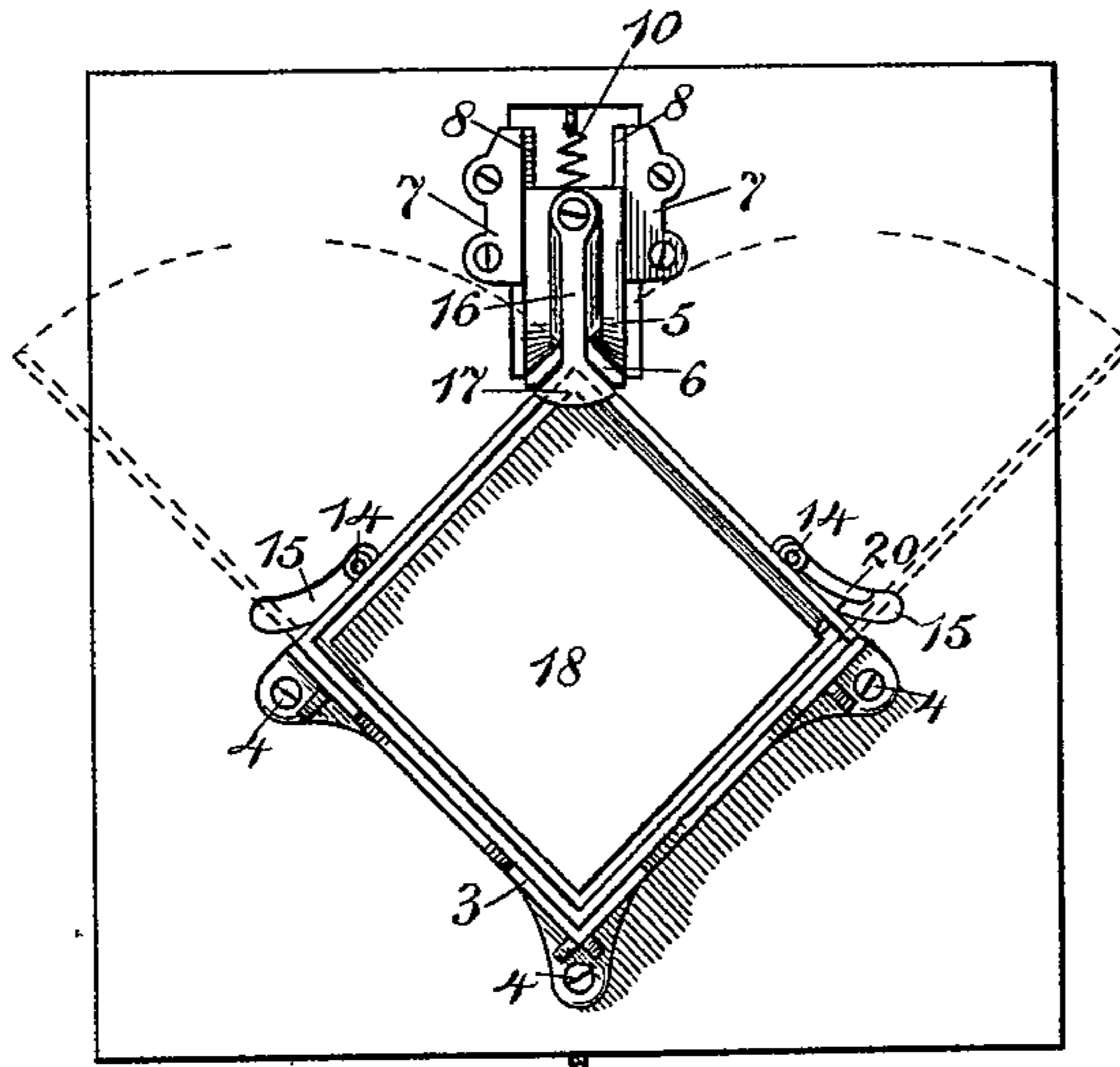

Fig. 4

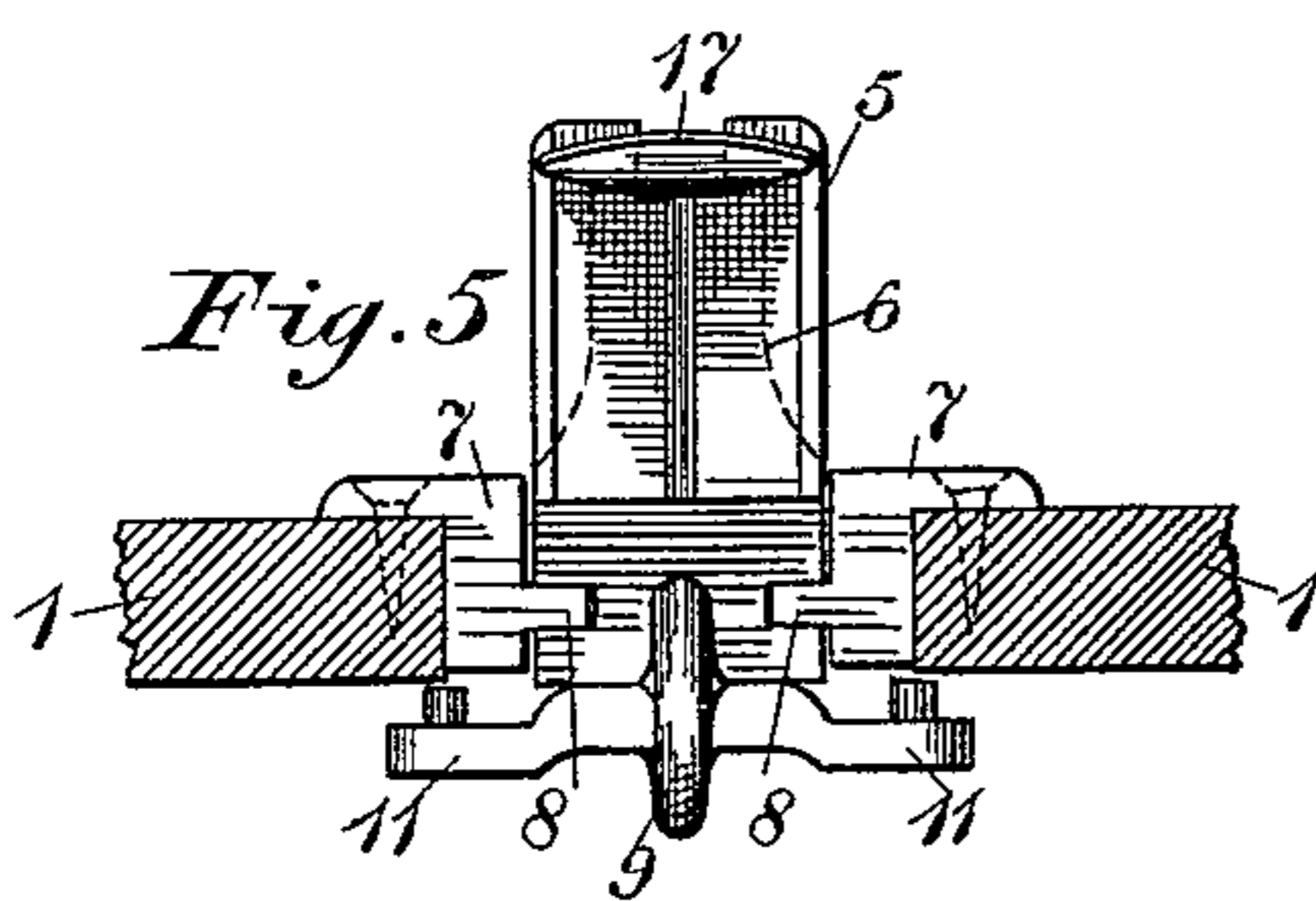

Fig. 5

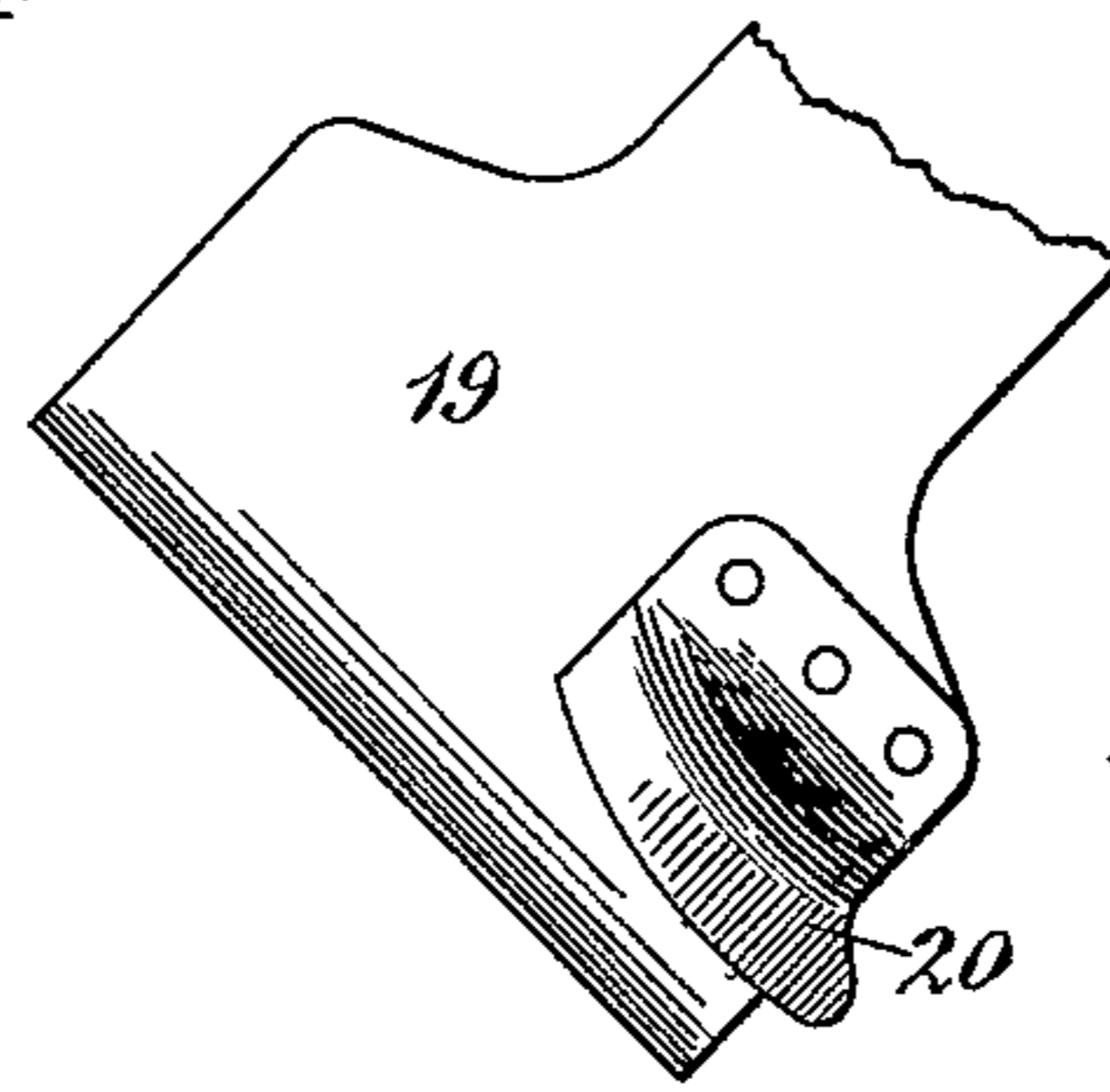

Fig. 6

Witnesses

Charles Priestman  
John Rowlett

Inventor

Walter O. Leach

Per W. J. Graham  
Atty.

# UNITED STATES PATENT OFFICE.

WALTER O. LEACH, OF COLDWATER, CANADA.

## PRESS FOR HONEY-SECTIONS.

SPECIFICATION forming part of Letters Patent No. 470,893, dated March 15, 1892.

Application filed May 22, 1891. Serial No. 393,780. (No model.)

*To all whom it may concern:*

Be it known that I, WALTER OLIVER LEACH, a subject of the Queen of Great Britain, residing at Coldwater, in the county of Simcoe, in the Province of Ontario, Canada, have invented a certain new and useful Combined Press and Foundation Setter for Honey-Sections for Bee-Hives, of which the following is a specification.

10 The object of my invention is, first, to provide a machine or means whereby bee-hive sections can be rapidly and effectually folded; second, to provide a means by which the sections can be folded and the "foundation" placed therein during the operation.

I attain the above objects by means of the device illustrated in the accompanying drawings, in which similar numbers of reference refer to similar parts throughout.

20 Figure 1 represents a plan of my machine. Fig. 2 represents the under or reverse side of my machine. Fig. 3 represents a side elevation; Fig. 4, a plan having the working parts in their positions when a section is folded thereby. Fig. 5 represents an elevation of the slide-block on the line A B, Fig. 1; and Fig. 6, a detail of a portion of the heater-plate to exhibit the incline thereon.

30 The table 1 of my invention is preferably formed as shown and composed of wood. The supports 2 at the front and rear are for the purpose of raising the table 1 a sufficient height to clear the mechanism on the under side from anything supporting my machine.

35 On the table 1 is secured the back-stop 3, which is preferably or suitably composed of metal secured to the table by screws 4, and in the position shown having the sides at right angles to one another and the angle bisected by the center line of the table 1. The sides of the back-stop 3 are about the length of the sides of the square sections to be folded therein.

45 At the rear side and in a suitable opening on the center line of the table 1 is provided the slide-block 5, having a corresponding small right-angled front face 6, as shown. The guide 7 on each side of the block 5 and secured to the table 1 has a tongue 8 thereon as a means by which said block 5 is guided to reciprocate. On the under side of the block

5 is formed an eye 9, to which a rope, cord, or other suitable connection is attached to operate it by. To the rear side, preferably, of the eye 9 is attached a spiral spring 10, secured at its opposite end to the table 1, so as to hold the block 5 rearward normally. The under side of the block 5 is provided with a bearing 11 at each side, to which is attached the connecting-bars 12, diverging toward the front of the table 1 and jointed at their opposite ends to levers 13, pivoted to said table.

60 On the free ends of the levers 13 are provided stud-pins 14, which extend upward through curved slots 15, formed in the table 1 and in such a position on each side as to become tangent with the swinging sides of the section, which are folded together by the stud-pins 14. The said stud-pins 14 incline outward from the lever 13, supporting them for the purpose of engaging the upper edge of the section and tending to press it downward.

70 The block 5 is provided with a spring 16, secured to the top thereof and having an enlarged end at 17 for the purpose of guiding the ends of the sections to match or properly interlock when being pressed together.

80 The rest 18 may be a square piece of wood of a thickness slightly less than half the depth of the section surrounding it when being folded together and of such size as to leave a convenient margin outside and inside the section.

85 In the table 1 is formed an elongated opening in the margin along one side of the rest 18 and toward the rear of the table, preferably. To the under side of the table 1 is hinged the heater-plate 19, which is formed, as shown, to project upward at right angles to occupy the opening in the table 1 and along one side of the rest 18. On the heater-plate 19 is formed an incline 20, hereinafter referred to more particularly, and at the opposite end a spring 21 is arranged to rest on the heater-plate 19, so as to occupy the slot in the table 1, but not to project above until operated for that purpose by the lift 22, secured on the free end of one of the levers 13 and at its under side, so as to engage the lower side of the incline 20 on the heater-plate 19, and as the said lift 22 moves along

the under side of the said incline 20 the plate 19 will be projected above the table 1 and between the rest 18 and the section, so that a piece of foundation resting on the rest 18 and slipped forward to touch the heater-plate 19 when elevated will have its edge melted by the heat of the plate 19, which is heated by a lamp, gas, spirit, or any other suitable means. When the lever 13 passes on and the lift 22 is carried under the incline 20, the plate 19 will naturally drop below the level of the rest 18 and permit the foundation to be slipped up to touch the section, to which, if done within proper time, the foundation sticks or sets by its melted margin hardening thereto. It will be noticed that the incline 20 is shorter along its curved edge than the arc of a circle traversed by the lift 22 on one of the levers 13, so that it passes under it and on the return to its normal position comes in contact with and pushes the incline downward, thereby compressing the spring 21.

By the skillful manipulation of the means described the sections can be folded and the foundation set in during the operation, thereby saving the second operation of setting the foundation by a separate and additional device.

The practical operation to be performed on the device is to place the strip to be folded with its center to correspond to the center of the table 1 and diagonally across the rest 18, as shown dotted in Fig. 1, then draw it toward the front of the machine, and forming a right angle therein to fit that of the back-stop 3, press it down with the margin between the rest 18 and the back stop 3. Next by means of the foot occupying a stirrup or other means of security on the rope attached to the eye 9 press downward, thereby moving the slide-block 5 forward, and the levers 13, carrying the stud-pins 14, operating through the medium of the connecting-bars 12, will fold in the ends of the strip from the position shown dotted in Fig. 4 to come together sufficiently close to be engaged by the right-angled face 6 on the block 5, and by the spring 16 pressing downward the ends will be matched and by the block 5 pressed into engagement. On releasing pressure on the rope the block 5, operated by the spring 10, will withdraw to its normal position and carry the stud-pins 14 outward and ready for the next strip to be folded.

Having now described my invention, what

I claim, and desire to secure by Letters Patent, is—

1. In combination, the slide-block supported in the table of the machine and having its front faces at right angles to one another, the means at its under side, as specified, to draw it forward, the spring to draw said block rearward, the spring along the top of said block to direct the section in folding, the slides in the table to direct the block, the connecting-bars jointed to said block, the levers jointed to said connecting-bars, and the stud-pins carried on said levers and projecting through slots in said table, substantially as shown and described.

2. In combination, the right-angled back-stop frame secured on the table, the slide-block supported in an opening on said table, the guides secured to the table to guide said block, the spring on the top of said block to guide the section-strip, the means on said block whereby it is drawn forward, means to draw it to the rear, the connecting-bars jointed to said block, the levers jointed to said connecting-bars, and the stud-pins carried on said levers and operating in slots in said table, substantially as and for the purpose set forth.

3. In combination, the right-angled back-stop, the rest-block secured within said back-stop, the heater-plate hinged to the table, a spring to adjust the position of said heater-plate, the incline on said heater-plate, the lift to operate the incline and the heater-plate supporting it, the lever carrying said lift and connected to the slide-block, and the said slide-block supported in guides on the table and having means to reciprocate it, substantially as and for the purpose set forth.

4. In combination, the back-stop secured to the table, the slide-block supported in guides, means to reciprocate said block, the levers connected to said slide block, the stud-pins carried by said levers, the heater-plate hinged to the table, the incline on said heater-plate, the lift on one of said levers to operate the incline on said heater-plate, and the rest secured to said table and within said back-stop, substantially as and for the purpose set forth.

WALTER O. LEACH.

Witnesses:

JOSEPH DOANE,  
STEPHEN J. LEACH.