

G. R. McCARTNEY.

COMBINED HONEYCOMB FOUNDATION FASTENER AND SECTION PRESS.

No. 585,477.

Patented June 29, 1897.

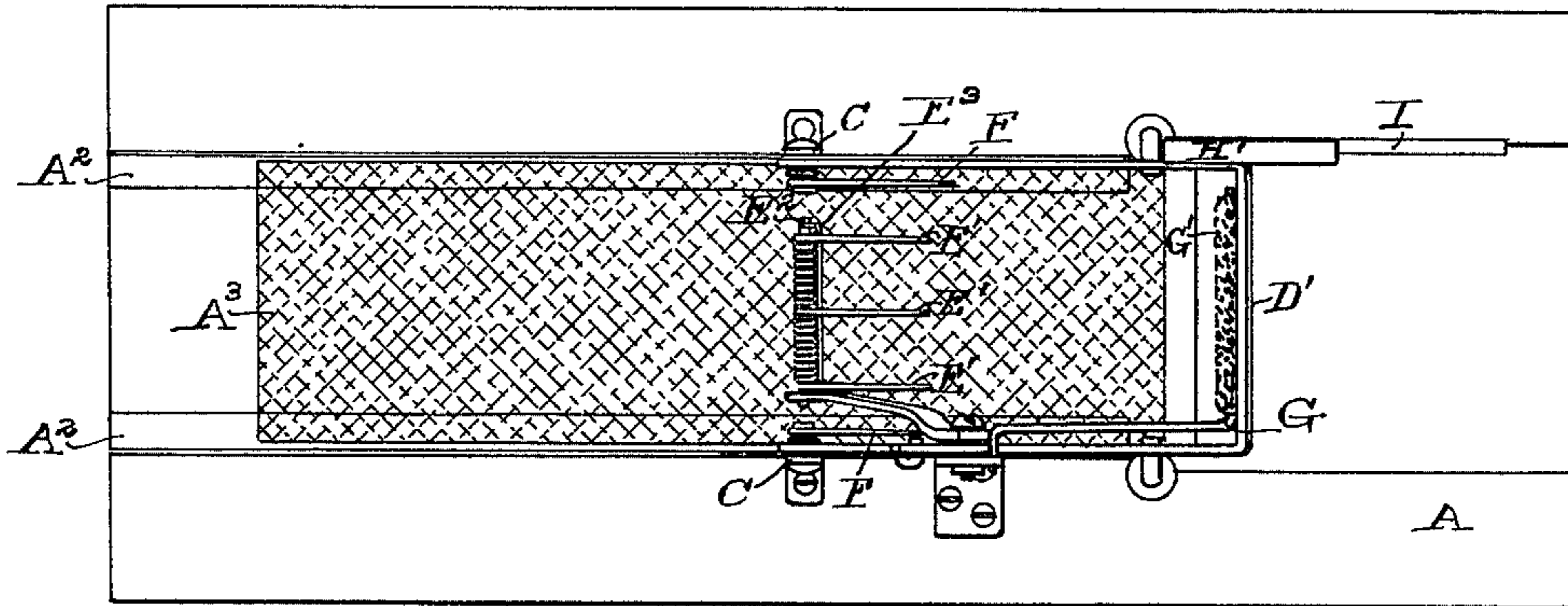

Fig. 1.

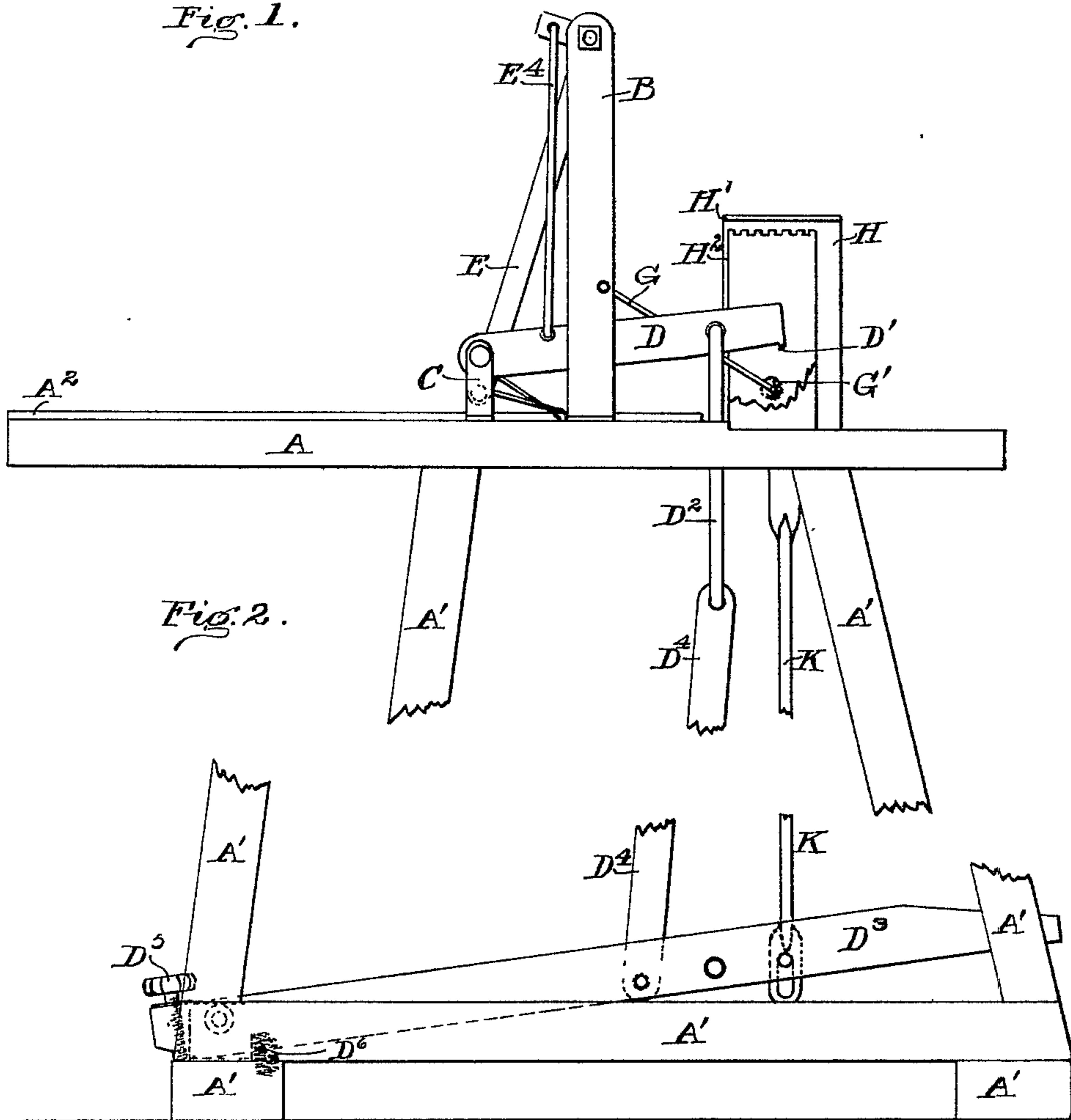

Fig. 2.

Witnesses:
 N. Bunker.
 Frank A. Tiebner

Inventor
 George R. McCartney
 Per Morrison & Miller
 Att'ys.

G. R. McCARTNEY.

COMBINED HONEYCOMB FOUNDATION FASTENER AND SECTION PRESS.

No. 585,477.

Patented June 29, 1897.

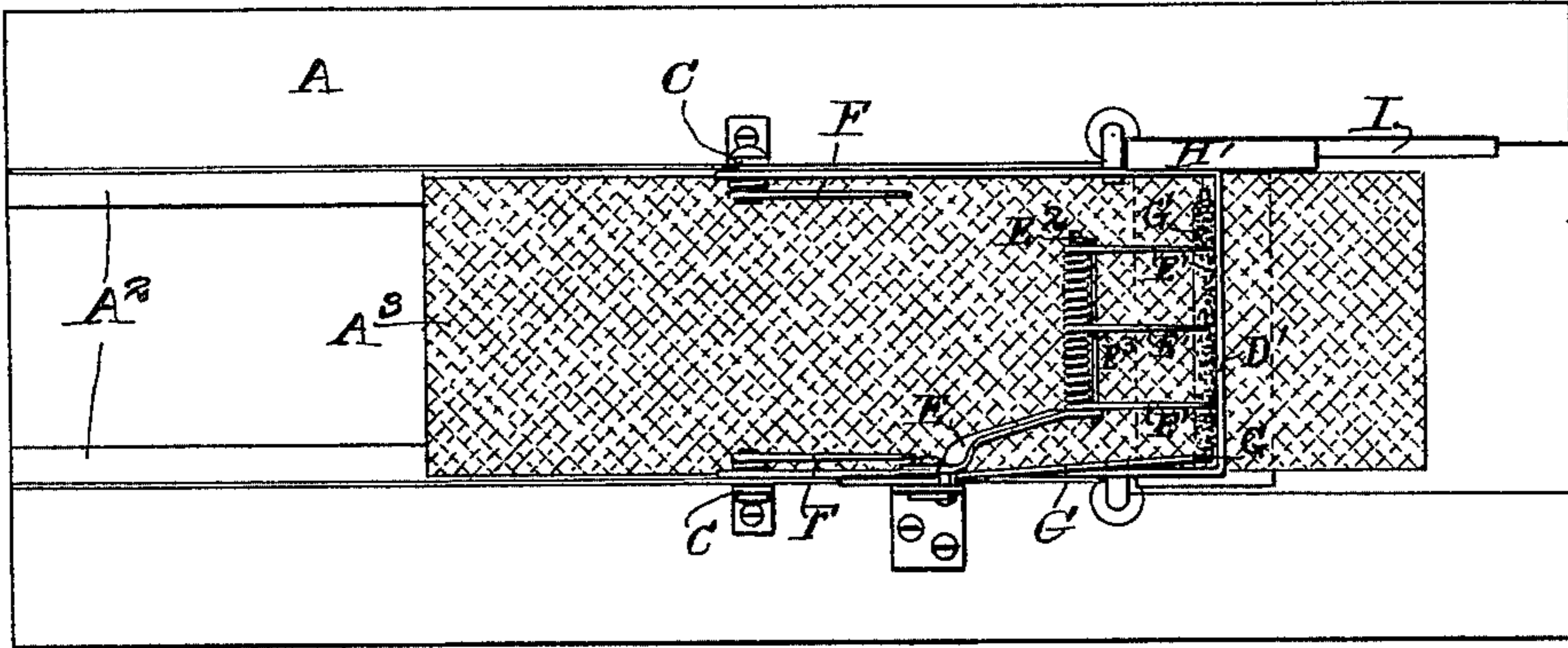

Fig. 3.

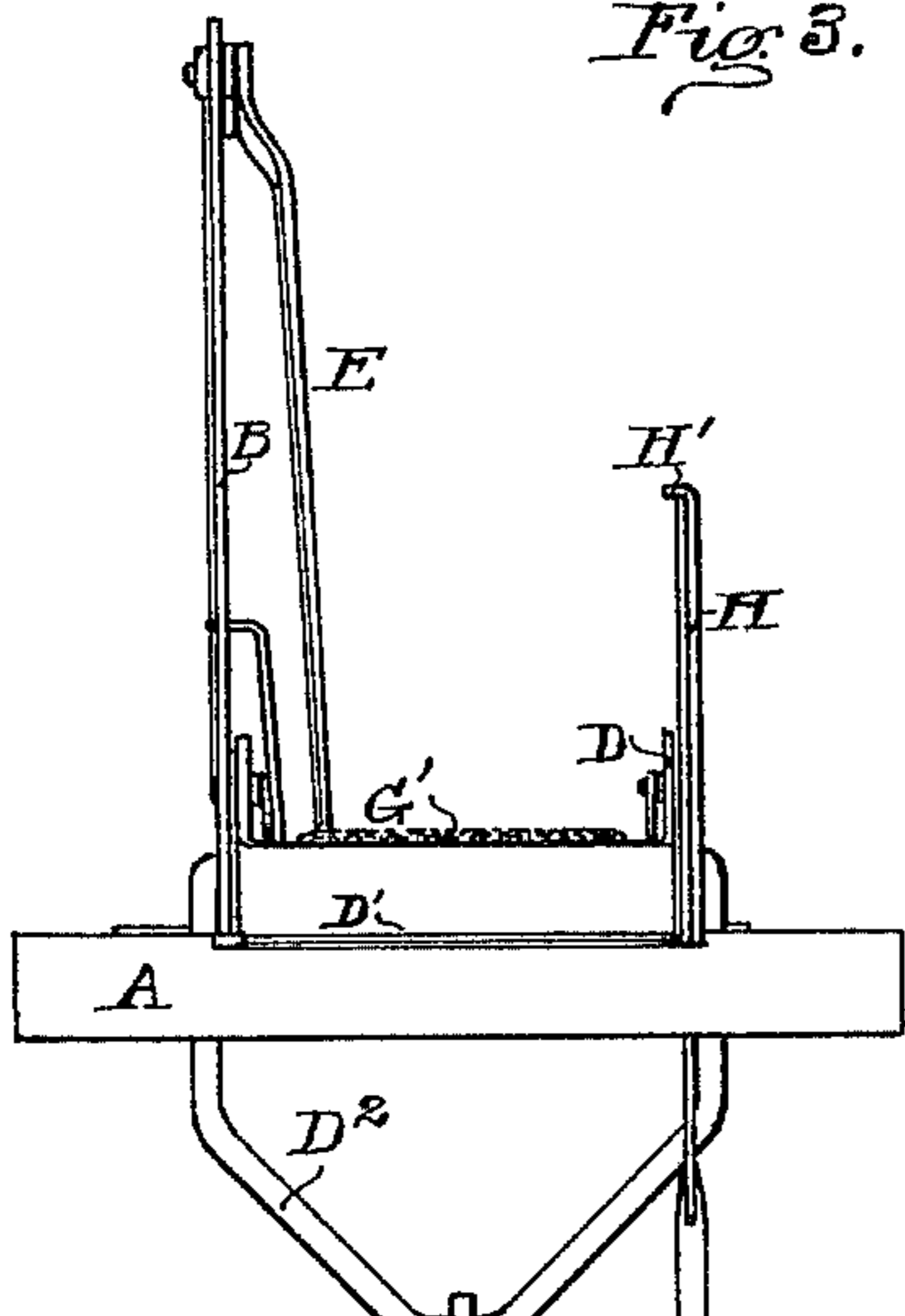

Fig. 5.

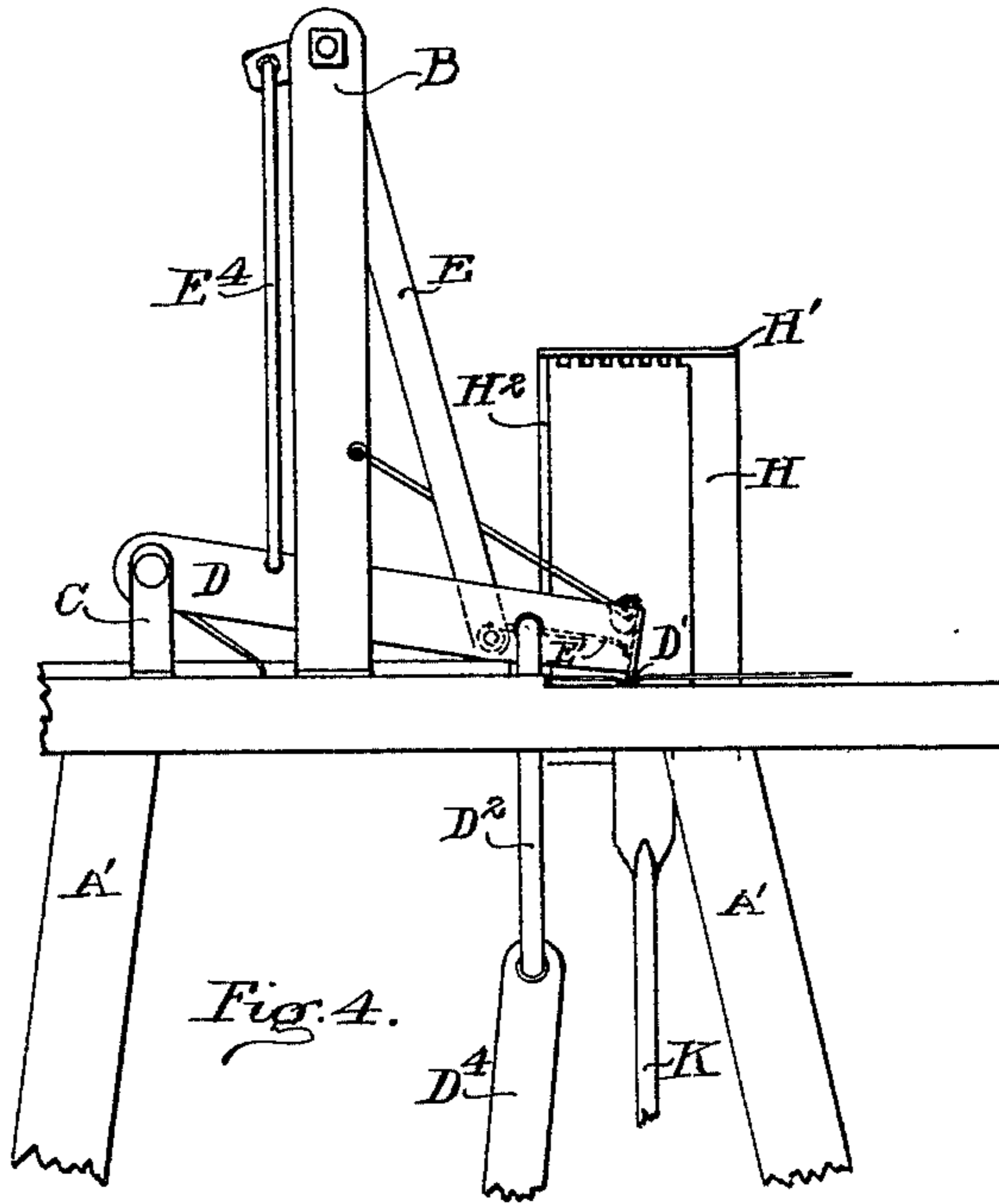
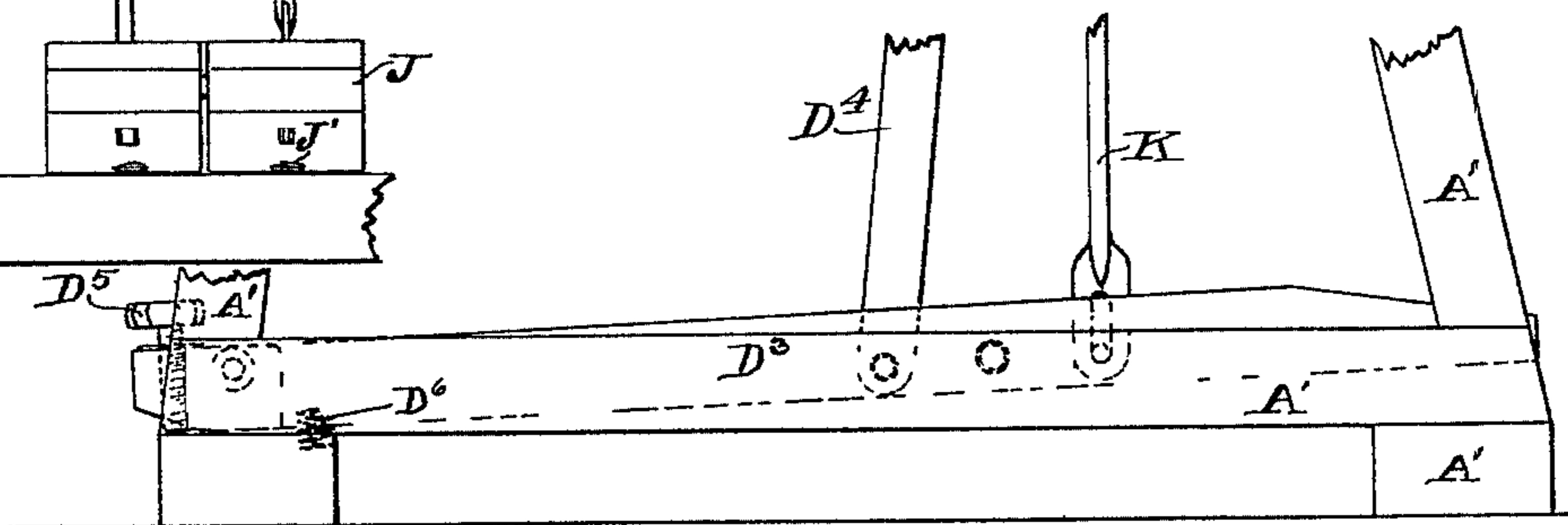

Fig. 4.



Witnesses:

R. Bunker
Frank A. Tichnor

Inventor

George R. McCartney,
Per Morrison & Miller,
Att'ys.

UNITED STATES PATENT OFFICE.

GEORGE R. McCARTNEY, OF ROCKFORD, ILLINOIS.

COMBINED HONEYCOMB-FOUNDATION FASTENER AND SECTION PRESS.

SPECIFICATION forming part of Letters Patent No. 585,477, dated June 29, 1897.

Application filed September 18, 1896. Serial No. 606,299. (No model)

To all whom it may concern:

Be it known that I, GEORGE R. McCARTNEY, a citizen of the United States, residing at Rockford, in the county of Winnebago and State of Illinois, have invented certain new and useful Improvements in a Combined Honeycomb-Foundation Fastener and Section-Press, of which the following is a specification.

The object of this invention is to produce a machine for fastening foundation-comb in honey-sections and also for pressing together the dovetailed ends of the piece from which the section is formed.

Referring to the accompanying drawings, which form a part hereof, Figure 1 is a plan view of the machine. Fig. 2 is a side elevation of the same, partially broken away. Fig. 3 is a plan view of the machine, representing the moving parts in a different position from that of Fig. 1. Fig. 4 is a side elevation, partially broken away, showing the several parts in the same position as in the preceding view. Fig. 5 is a front elevation following the two preceding figures.

Similar letters refer to like parts throughout the several views.

A is a table supported by the framework A' and provided with the comb-guides A².

A³ is the sheet of prepared comb-foundation material.

B is a fixed upright secured to the table A at one side of the comb guides A².

C are two posts also secured to the table A at opposite sides of the comb guides A².

D is a presser-bar pivoted between the posts C, provided with the presser-blade D'.

D² is a yoke pivotally connected with the presser-bar D.

D³ is a pivoted foot-lever in the lower part of the framework A'.

D⁴ is a link connecting the yoke D² with the foot lever D³.

D⁵ is a hand-screw threaded through the foot-lever D³ for adjustably limiting the upward throw of the foot lever D³.

D⁶ is a coiled spring interposed between the foot lever D³ and the frame for raising the forward end of that lever when pressure of the foot of the operator is withdrawn.

E is a right-angle lever pivoted at its angle in the upper end of the fixed upright B. Its longer arm, extending downward, carries a

series of feeding pawls E' for the sheet of prepared foundation A³. These pawls are loosely mounted upon a horizontally extending pin E², fixed in and extending from the long arm of the lever E, being formed from wire which is coiled around the pin E², giving the pawls a sufficient bearing thereon and retaining them at a proper distance apart.

E³ is a supporting-wire extending parallel with the pin E² and is secured to that pin. This wire lies under the feeding-pawls E', and when the latter are moved to a point near their extreme forward position causes them to raise free from the sheet of prepared foundation A³ when the descending presser-blade is about to enter and sever the wax sheet A³.

E⁴ is a link connecting the short arm of the right-angle lever E with the presser-bar D.

F are detent pawls, one of which is loosely pivoted upon each of the bearings of the presser-bar, and their object is to prevent a backward movement of the sheet of prepared foundation-wax A³, though not interfering with its forward movement.

G is a moistening bar attached to the upright B, and extending forward lies parallel with the presser-blade D', where the bar is wrapped with a sponge G' to furnish moisture to the presser blade at each downward movement of the latter. The bar G is pivoted to the upright B to permit an adjustment of the position of the moistener G' relative to the presser blade D'. Thus moistening the presser-blade prevents its sticking to the wax of the foundation material A³.

The bar G is held in any desired position by its frictional engagement with its bearings in the upright B.

H is the presser block, provided with the inwardly-projecting edge H' at its upper end and the gage edge H² at the side.

I is a narrow opening through the table, within which the presser-block H lies.

J is a pivoted foot lever located in the lower part of the frame adjacent to the foot-lever D³.

J' is a spring for holding the forward end of the lever J elevated.

K is a rod connecting the foot-lever J with the presser block H, having a slotted connection with the lever and a rigid connection with the presser block.

The length of the narrow opening I is sufficient to permit the presser-block to be drawn forward out of the way of the foundation fastener when the latter is in operation and when it is not desirable to use the section press at the same time. The presser-block II does not require as much vertical movement as the presser bar D, and the foot lever J therefore moves freely the length of the slot of the connecting rod K, and striking against the bottom of that slot gives a slight downward movement to the presser block at the latter part of the lever's depression.

In operation the section blank, ready to be put together, is placed in proper position under the presser blade D' and a sheet of prepared comb foundation A³ placed between the guides A² and under the feeding pawls E'. The sponge of the moistener-bar G is dampened and the machine is ready for work. A downward pressure upon the foot lever D³ causes the presser-blade D' to descend, receiving moisture as it passes the bar G. The feeding pawls E' slide the sheet of foundation material forward under the descending presser blade until they approach the forward limit of their throw, when the rest E³ causes the points of the feeding pawls E' to be raised from the foundation material, permitting it to stop just as the presser blade D' is forced into its substance. The blade cuts off as much of the sheet of foundation as has been passed forward by the feeding pawls and forces a little edge of the wax in close contact with the wood of the section to which it adheres, the moisture on the blade permitting it to free itself from the wax. The sides of the section are now bent into position and the tenons and slots of its ends fitted together. The presser block II is brought into its forward position in the slot I and the foot of the operator applied to the foot lever J, bringing the inwardly-projecting edge II' of the presser-block into contact with the tenons and slots of the upper horizontal portion of the section and forcing the ends firmly together. The section is then inverted and a narrow strip of foundation secured in the same manner opposite to the first, and both strips are bent at right angles to their first position to lie within the section.

The width of the strips of foundation to be set in the section is governed by the movement of the foot-lever D³, which is regulated by the hand screw D⁵.

When it is desirable to perform both the operation of setting the foundation strip and pressing the ends of the section together in one operation, the two foot levers D³ and J are fastened together and the presser-blade and presser-block descend together.

The slotted connection between the treadle J and its connecting-rod K permits a considerable descending movement of the lever J before the pressure is applied to presser-block H.

I claim—

1. In a comb-foundation fastener for honey sections, in combination, a presser-blade, means for operating the presser blade, a feeding pawl for the comb foundation and means for operating the feeding pawl substantially as and for the purpose specified. 70

2. In a comb foundation fastener for honey-sections, in combination, a presser blade, a lever for operating the presser blade, a feeding pawl for the comb foundation and a lever for actuating the feeding pawl substantially as and for the purpose specified. 75

3. In a comb-foundation fastener for honey-sections, in combination, a pivoted presser blade, a foot-lever, a connection between the presser blade and the lever, a pivoted right angle lever, a connecting-rod between the presser blade and one arm of the right-angle lever and a feeding pawl for the comb foundation, supported by the other arm of the right-angle lever substantially as and for the purpose specified. 80

4. In a comb foundation fastener for honey-sections, in combination, a pivoted presser-blade, a moistener for the presser blade, a foot lever, a connection between the presser-blade and the lever, a pivoted right angle lever, a connecting rod between the presser-blade and one arm of the right angle lever and a feeding pawl for the comb-foundation, supported by the other arm of the right angle lever substantially as and for the purpose specified. 85 90 95 100

5. In a comb-foundation fastener for honey-sections, in combination, a pivoted presser-blade, a foot lever, a spring for the lever, a connection between the presser-blade and the foot-lever, guides for the comb foundation, a pivoted right-angle lever, a connecting-rod between the presser-blade and the short arm of the right-angle lever, a pin extending from the long arm of said lever, a gravity feeding-pawl loosely mounted on said pin, a stop on the pin for limiting the free movement of the feeding pawl and a detent-pawl for engaging the comb foundation and preventing a backward movement thereof substantially as and for the purpose specified. 105 110 115

6. In a press for honey sections, in combination, a supporting frame, a presser-block, capable of a movement relative to the supporting-frame, means for operating the presser-block, a presser-blade, and means for operating the presser-blade, substantially as and for the purpose specified. 120

7. In a press for honey-sections, in combination, a supporting frame, a presser block capable of a sliding movement, a foot lever, a connection between the foot lever and the presser block, a presser blade, and means for operating the presser-blade, substantially as and for the purpose specified. 125

GEORGE R. McCARTNEY.

Witnesses:

L. L. MILLER,
NELLIE BUNKER.