

(No Model.)

E. B. WEED.

MACHINE FOR MAKING ARTIFICIAL HONEYCOMB FOUNDATIONS.

No. 598,060.

Patented Jan. 25, 1898.

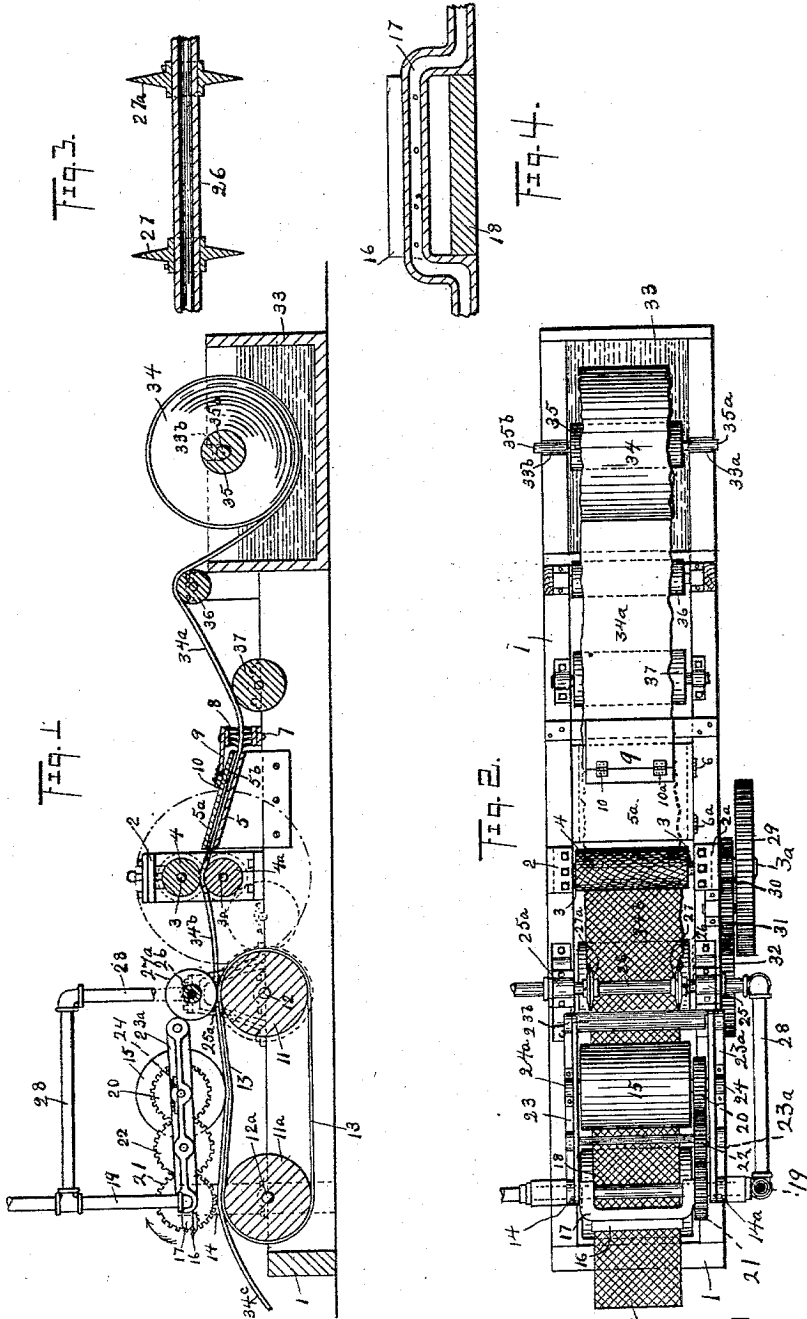

WITNESSES

Belle S. Loring.

A. E. Emertel

INVENTOR.

Edward B. Weed,

By J. A. Osborne & Co.

ATTORNEY.

UNITED STATES PATENT OFFICE.

EDWARD B. WEED, OF MEDINA, OHIO, ASSIGNOR TO THE A. I. ROOT COMPANY, OF SAME PLACE.

MACHINE FOR MAKING ARTIFICIAL HONEYCOMB FOUNDATIONS.

SPECIFICATION forming part of Letters Patent No. 598,060, dated January 25, 1898.

Application filed February 15, 1896. Renewed December 29, 1897. Serial No. 664,450. (No model.)

To all whom it may concern:

Be it known that I, EDWARD B. WEED, a citizen of the United States, residing at Medina, in the county of Medina, State of Ohio, have invented certain new and useful Improvements in Machines for Making Artificial Honeycomb Foundations, of which the following, with the accompanying drawings, is a full, clear, and exact specification.

My invention relates to machines for making artificial comb foundations from sheet-wax.

In making artificial comb foundations sheets of wax are passed between die-rolls to give to the wax sheets a favosed or honeycombed surface, and the favosed sheets are then cut to a required size. Great difficulty has been experienced in feeding the wax sheets evenly and continuously to the die-rolls, and in pulling the sheets off evenly as they come from the die-rolls, and in keeping the honeycombed surfaces of the sheets in perfect condition while pulling the sheets from the die-rolls, and in cutting them.

The objects of my invention are, first, to provide for feeding sheets of wax continuously and evenly to the die-rolls; second, to remove from the sheet-wax all particles adhering to its surfaces before the wax passes between the die-rolls; third, to take the wax from the die-rolls evenly and continuously without marring or disturbing the honeycombed surfaces, and, fourth, to cut the favosed wax sheets to required sizes accurately without injuring the comb foundation.

My invention consists in the construction and combination of parts described herein and defined in the claims.

Reference is here made to the claims for a definition of my invention.

In the drawings, Figure 1 illustrates a longitudinal vertical section of a machine embodying my invention. Fig. 2 is a plan of the same. Fig. 3 is an enlarged axial section of the trimming-knives and their heating-pipe, and Fig. 4 is an enlarged view of the cutting-knife with its heating-pipe in section.

In the different figures of the drawings like reference characters refer to like parts.

1 is the machine-frame.
2 2^a are standards, in which are journaled

the axles 3 3^a of the die-rolls 4 4^a. The die-rolls have their faces so formed as to make the surfaces of wax sheets passing between them favosed or honeycombed. 55

Immediately in front of the die-rolls is a guide, consisting of the floor 5, having a top 5^a hinged thereto by means of hinges 6 6^a, leaving a space 5^b between the floor and the top, through which sheets of wax may pass freely. The guide conducts the wax sheets to the die-rolls. 60

To the machine-frame is secured a brush 7, with its bristle side up, and a brush 8, with its bristles projecting downwardly, is held above the lower brush by means of a holder 9, that is hinged to the top 5^a of the guide by means of the hinges 10 10^a. The function of the brushes is to clean the surfaces of the wax sheets passing between them of all foreign particles before reaching the die-rolls. The upper brush is hinged so that it may be thrown back out of the way in case of accident and to facilitate cleaning both brushes when desired. 75

Back of the die-rolls are two rollers 11 11^a, having their axles 12 12^a journaled upon the machine-frame. An endless carrier web or belt 13 passes around the rollers 11 and 11^a and is driven through the roller 11. The endless carrier 13 is made of canvas belting, rubber belting, or other suitable material. The favosed sheet of wax is drawn away from the die-rolls by the endless carrier. 80

Standards 14 14^a at the back end of the machine support the cut-off device and the hinged frame that carries a floating gripping-roller 15. Said cut-off device consists of a knife 16, that is fixed to the offset pipe 17 and rotates with said pipe around its axis. For the purpose of giving strength and rigidity to the cut-off device the offset pipe is provided with an axial brace 18. The offset pipe, to which the knife 16 is attached, is connected with a steam or a hot-water pipe 19 for keeping the knife heated to a degree that will prevent wax from adhering to it. The knife rotates in the direction of the arrow, Fig. 1. Upon the end of the gripping-roller 15 is a gear 20. A gear 21 is fixed upon the pipe 17 of the cut-off knife, and an intermediate gear 22 meshes with the gears 20 and 85
90
95
100

21. The roller 15 is driven by frictional contact with the endless carrier 13 or by a wax sheet that travels with the endless carrier between it and the gripping-roller. The cut-off knife is operated by the roller 15 through the gears 20, 22, and 21. Said roller 15 and the gears 20 and 22 are carried by the hinged frame. The hinged frame consists of two side bars 23 23^a, connected at the free end by the cross bar or tie 23^b. The ends of the pipe 17 project through bearings in the ends of the bars 23 23^a, upon which pipe the frame is adapted to swing.

The size of the roller 15 controls the rapidity of revolution of the cut-off knife 16 and so determines the length of foundation-strips cut by the machine. To adapt the machine to cutting foundation-strips of various lengths, the gripping-roller 15 is interchangeable with like rollers 15 of other sizes. To make the rollers 15 interchangeable, the upper side of the boxes 24 24^a are made removable.

In front of the hinged frame are standards 25 25^a, having journal-boxes at their upper ends, in which turns the hollow shaft 26. Fixed upon this hollow shaft are circular trimming-knives 27 27^a, whose edges rest on the endless web or carrier and are revolved by frictional contact with the carrier or the sheet-wax to trim the edges of the sheet-wax. The hollow shaft has a steam or hot-water connection 28 to keep the trimming-knives warm to facilitate their cutting and to prevent the sticking of wax thereto.

The machine is driven by power applied through the drive-gear 29, that is fixed upon the shaft 3^a of the die-roll 4^a. The endless carrier is driven from the shaft 3^a through the gear 30, fixed upon said shaft, the intermediate gear 31, and the gear 32, that is fixed upon the shaft 12 of the roller or drum 11. The intermediate gear 31 is interposed between the gears 30 and 32 to cause the endless carrier to travel in the direction of the turn of the die-rolls.

At the front end of the frame is a tank or vat 33, containing warm water, in which a roll of wax 34 is immersed. The purpose of the warm water is to temper the wax to be operated upon by the die-rolls. The wax sheets to be favosed are rolled upon a roller 35 or a suitable reel, having spindles 35^a 35^b, that drop into slots 33^a 33^b, formed in the sides of the vat to receive the spindles. At the inner end of the tank is a roller 36 and a like roller 37 in front of the brushes, that are idlers and serve to prevent the sheet of wax from dragging over the edge of the tank and from unduly sagging.

The operation of my improvements will be understood readily from the description given.

A roll of sheet-wax is held in the vat containing warm water to temper the wax, as described. The end of the roll is pulled out and the upper hinged side of the guide is thrown back to allow the introduction of the end of

the roll to the die-rolls. The hinged side of the guide is then closed over the wax sheet and the cleaning-brushes placed in contact with the sheet of wax in front of the guide. The machine will then be turned until the end of the wax sheet shall have passed far enough through the die-rolls to be laid on the carrier-belt and reach under the gripping-roller. As the machine is driven the gripping of the die-rolls upon the sheet of wax will pull it from the tank, and the favosed sheet will be gripped between the carrier-belt and the gripping-roller and pulled from the die-rolls. Each revolution of the cutting-knife cuts off a foundation-sheet to a required size, while the width of the sheets will be made even by the trimming-knives. The sheet of wax as drawn from the roll 34 in the vat is shown as having a smooth surface with uneven edges, as at 34^a, before reaching the die-rolls. After passing between the die-rolls the surfaces are favosed or honeycombed, as illustrated at 34^b and 34^c, while from the trimming-knives the edges are even, as illustrated at 34^c.

My invention may take on various modifications in details of construction, and I do not therefore limit myself to the construction and arrangement described.

What I claim as my invention, and desire to secure by Letters Patent, is—

1. In combination with the die-rolls of a comb-foundation machine, a gripping device consisting of rollers, an endless carrier that travels over the rollers, and a roller above the endless carrier between which and the endless carrier favosed sheets of wax may be gripped and pulled from the die-rolls, substantially as described.

2. In combination with the die-rolls of a comb-foundation machine, a gripping device consisting of an endless carrier and a floating gripping-roller between which and the endless carrier favosed sheets of wax may be gripped by frictional contact and pulled away from the die-rolls, substantially as described.

3. In combination with the die-rolls of a comb-foundation machine, rollers, an endless carrier that is driven by the rollers, a frame hinged at one end above the endless carrier and having a roller journaled at its free end, substantially as described.

4. In combination with the die-rolls of a comb-foundation machine, an endless carrier, a gripping-roller above the endless carrier between which and the endless carrier favosed sheets may be gripped and pulled from the die-rolls, and a knife above the endless carrier adapted to cut the favosed sheets into comb foundations of a required size, substantially as described.

5. In combination with the die-rolls of a comb-foundation machine, an endless carrier and a roller in frictional contact therewith between which and the endless carrier favosed sheets may be gripped and pulled from the die-rolls, a knife to cut the favosed sheets into comb foundations of a required size, and

means for heating the knife, substantially as described.

6. In combination with the die-rolls of a comb-foundation machine, an endless carrier with a roller above it to grip favosed sheets and pull them away from the dies, knives for trimming the edges of the favosed sheets, a knife to cut the favosed sheets into comb foundations of a required size, and means for heating the said knives, substantially as described.

7. The combination, in a comb-foundation machine, of die-rolls, and a guide leading to the die-rolls, with an endless carrier and a gripping-roller to take the favosed sheets of wax from the die-rolls, substantially as described.

8. The combination, in a comb-foundation machine, of die-rolls, a guide to the die-rolls,

an endless carrier and a roller to take the favosed sheets of wax from the die-rolls, and an automatically-operated knife for cutting the favosed sheet into foundations of uniform size, substantially as described.

9. The combination, in a comb-foundation machine, of die-rolls, a guide leading to the die-rolls, a brush located before the die-rolls, means for pulling wax sheets from the die-rolls, and a knife to cut the wax sheet to foundations of uniform size, substantially as described.

In testimony whereof I affix my signature, in the presence of two witnesses, this 5th day of February, 1896.

EDWARD B. WEED.

Witnesses:

W. P. ROOT,
E. R. ROOT.