

A. C. MILLER.
HONEYCOMB UNCAPPING MACHINE.

(Application filed Apr 16, 1901.)

(No Model.)

2 Sheets Sheet 1.

Fig. 2.

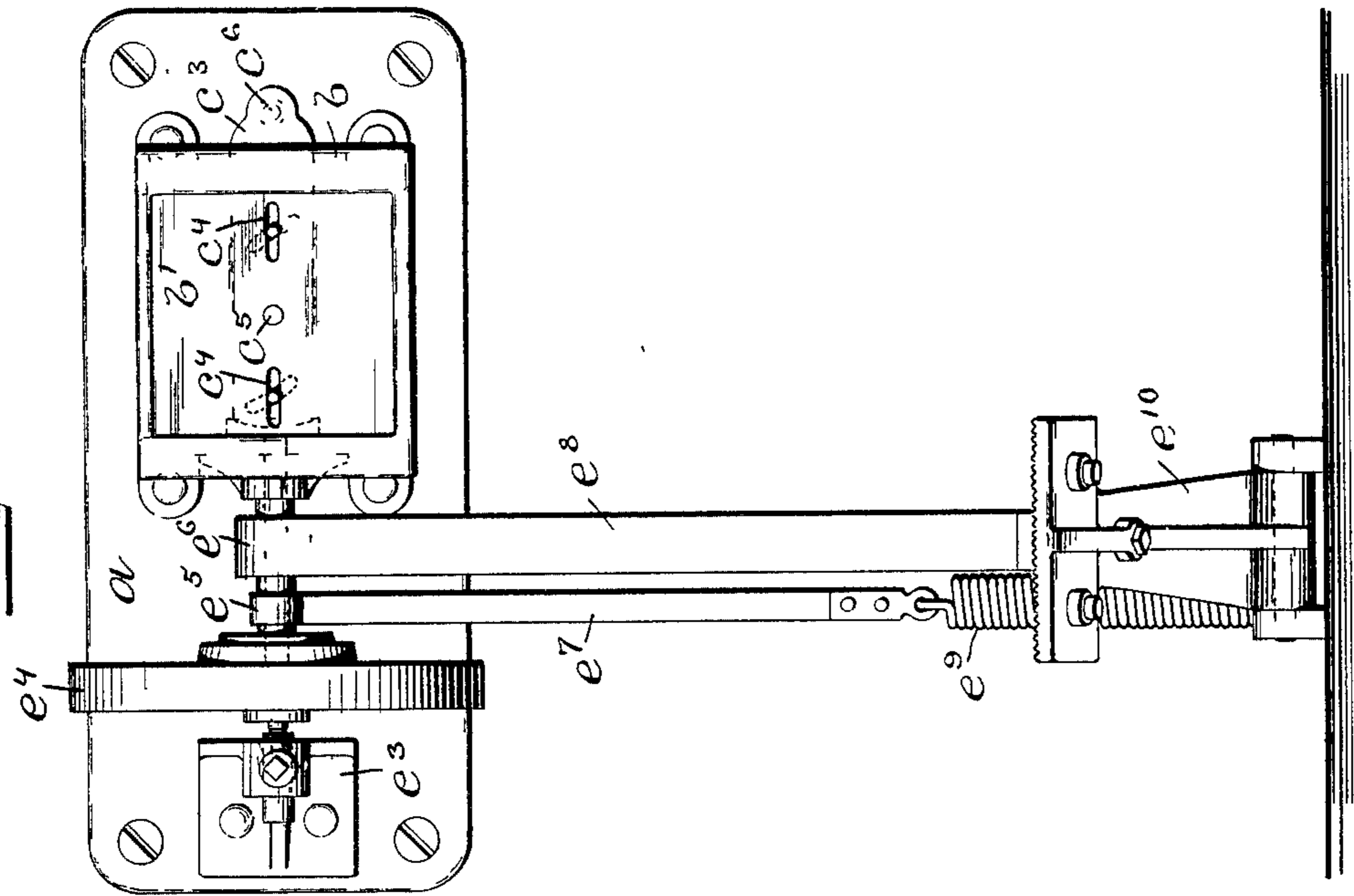
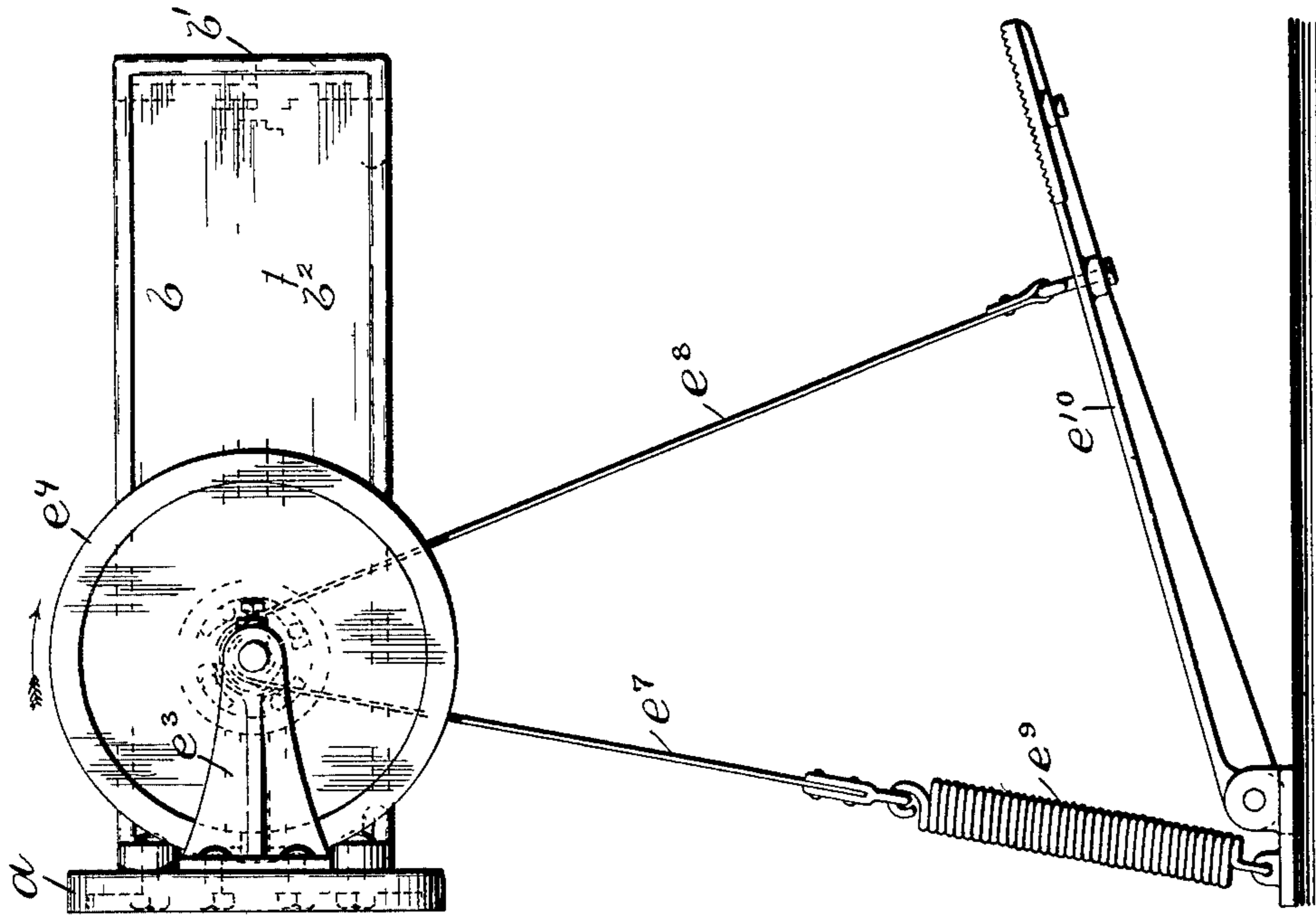

Fig. 1.



WITNESSES:

Chas H. Luther Jr
Ada E. Hagerty.

INVENTOR:

Arthur C. Miller
Joseph A. Miller & Co.
ATTORNEYS:

A. C. MILLER.
HONEYCOMB UNCAPPING MACHINE.

(Application filed Apr. 16, 1901.)

(No Model.)

2 Sheets Sheet 2.

Fig. 3 -

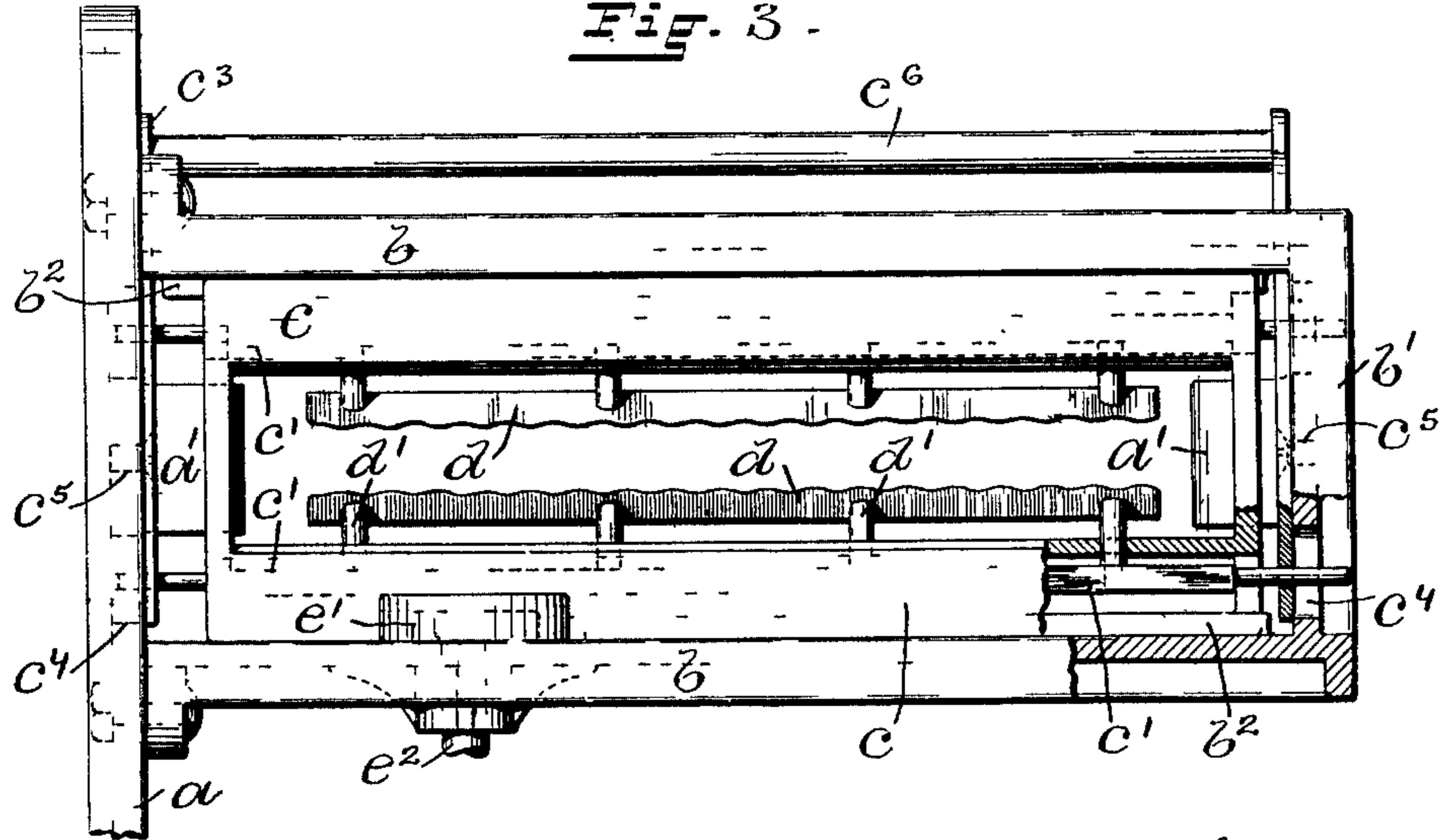

Fig. 4.

Fig. 5.

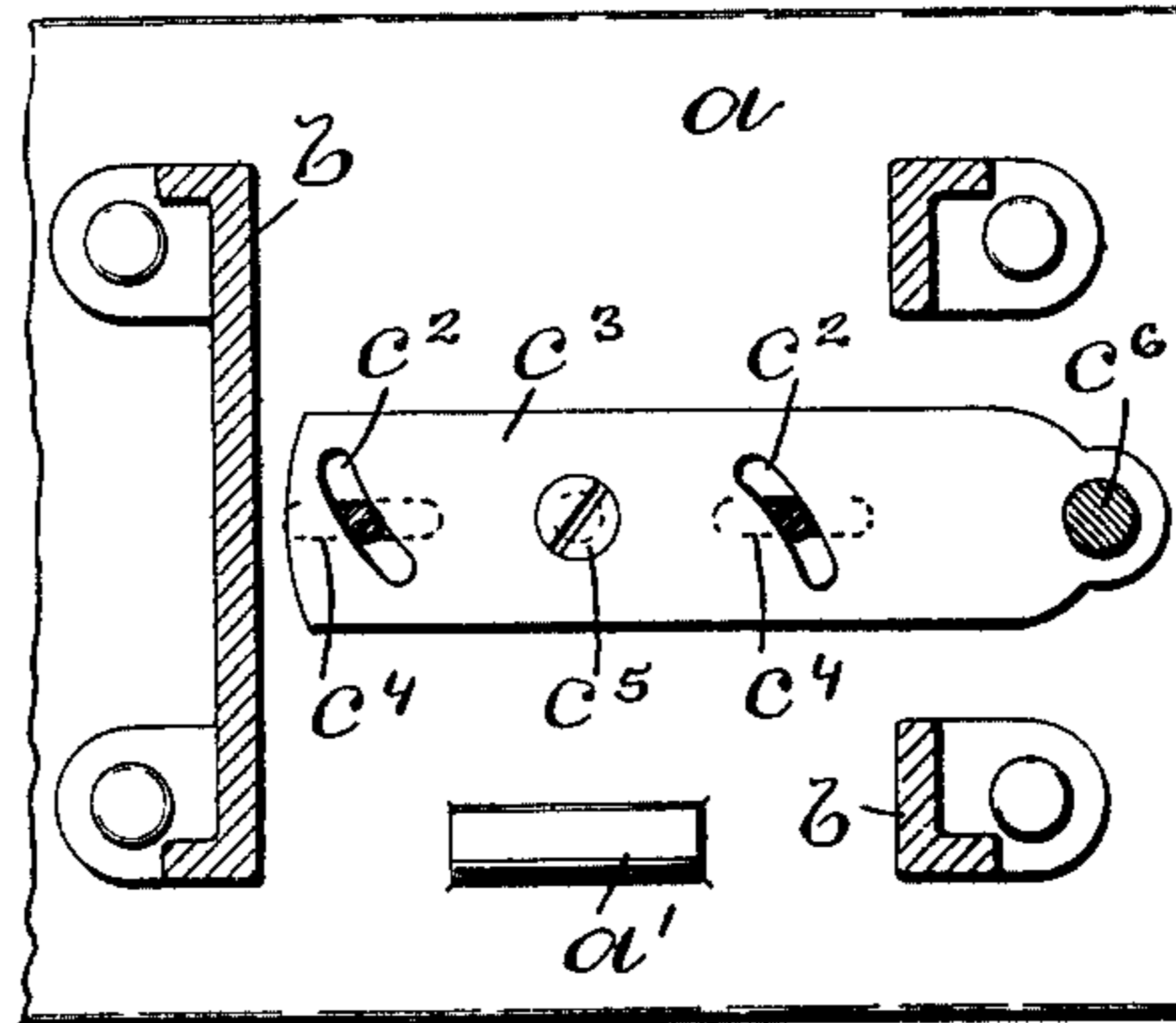
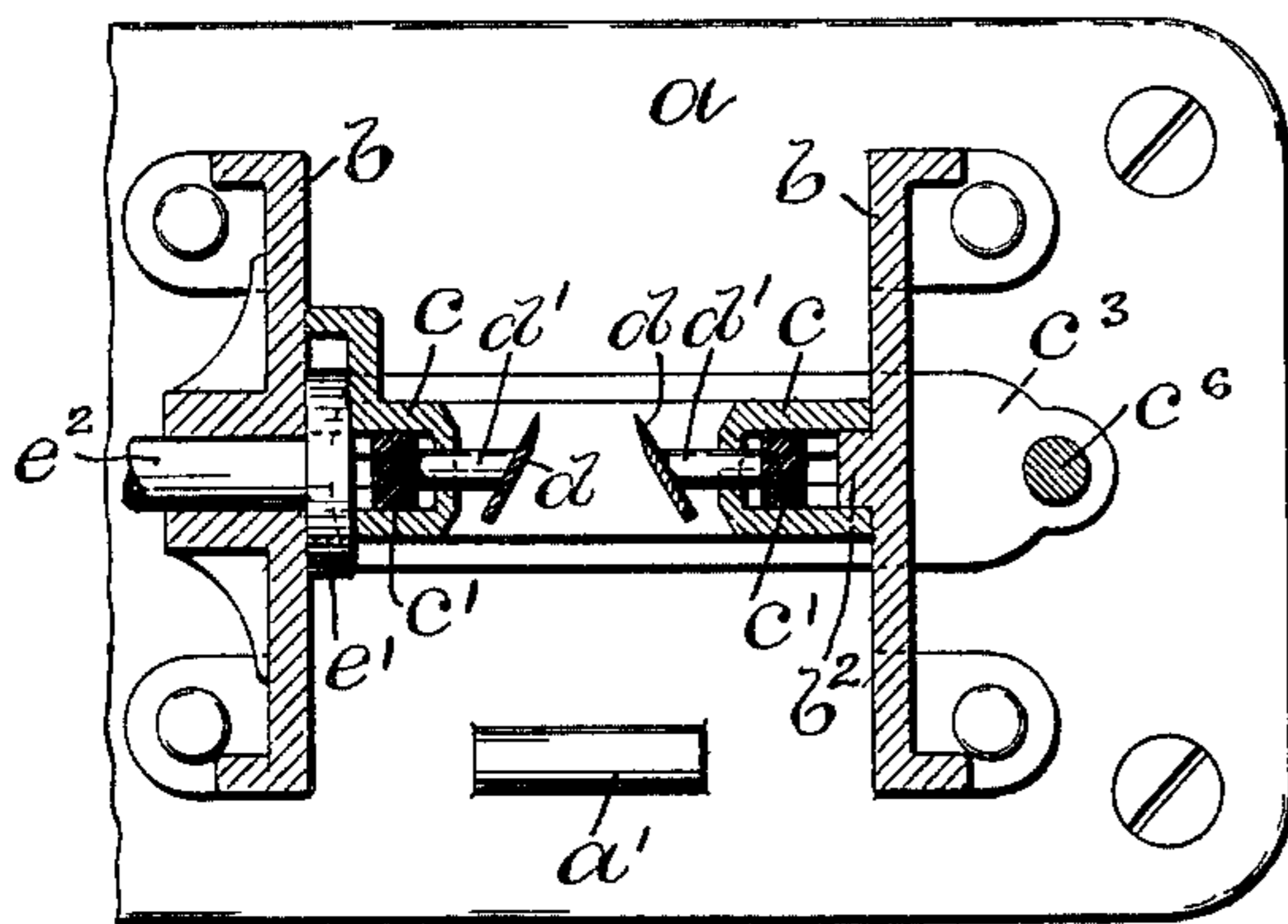
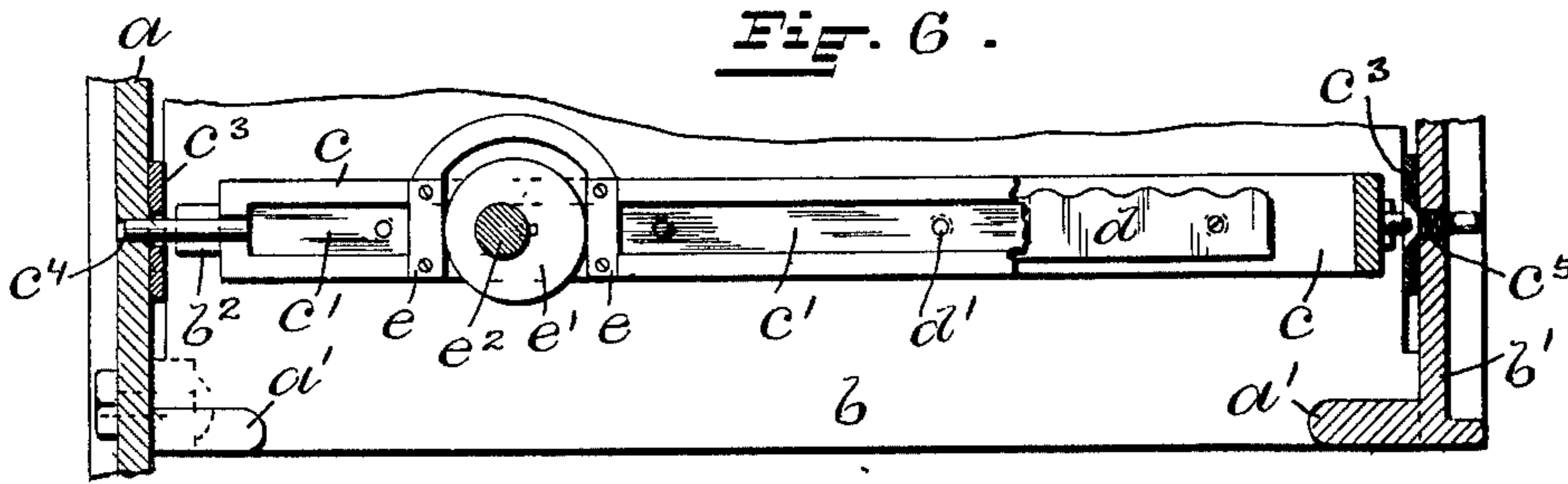

Fig. 6.



WITNESSES:

Chas. H. Luther, Jr.
Ada E. Hagerty.

INVENTOR:

Arthur C. Miller
by Joseph A. Miller & Co.
ATTORNEYS:

UNITED STATES PATENT OFFICE.

ARTHUR C. MILLER, OF NEWTON, MASSACHUSETTS.

HONEYCOMB-UNCAPPING MACHINE.

SPECIFICATION forming part of Letters Patent No. 711,223, dated October 14, 1902.

Application filed April 16, 1901. Serial No. 56 096. (No model.)

To all whom it may concern:

Be it known that I, ARTHUR C. MILLER, a citizen of the United States, residing at Newton, in the county of Middlesex and State of Massachusetts, have invented a new and useful Improvement in Honeycomb-Uncapping Machines, of which the following is a specification.

To facilitate the extraction of honey from the comb, the wax closing the cells has to be removed. This has usually been done by cutting off caps closing the cells by means of the uncapping-knife.

The object of this invention is to facilitate the operation of uncapping; and to this end the invention consists in the peculiar and novel construction of a machine and the combination of the parts whereby the two sides of the comb may be uncapped, as will be more fully set forth hereinafter.

Figure 1 is a side view of the machine, showing the foot actuating mechanism. Fig. 2 is a front view of the same. Fig. 3 is a plan view, partly in section, of the essential part of the machine. Fig. 4 is a transverse sectional view of the uncapping machine, showing the reciprocating frame supporting the uncapping-knives. Fig. 5 is a transverse sectional view showing the rocking frame by which the positions of the uncapping-knives are controlled. Fig. 6 is a longitudinal sectional view showing the reciprocating knife-supporting frame.

Similar marks of reference indicate corresponding parts in all the figures.

In my present invention I support in a suitable casing a frame to which reciprocating motion is imparted by suitable mechanism, shown in the drawings as a foot-treadle mechanism rotating an eccentric, and have connected two knives obliquely in opposite directions on bars which are controlled by a rocking frame by which the positions of the knives may be adjusted.

I do not wish to confine myself to the mechanism shown in the drawings for reciprocating the knives or to the exact construction of the means for adjusting the knives, as they may be changed or other means adopted to reciprocate and adjust the knives to the comb without materially affecting the operation of the machine.

In the drawings, *a* indicates a bed-plate, and *b b* the two sides, secured at one end to the bed plate and connected by the end *b'*. The guides *a' a'* project from the bed-plate *a* at one end and from the end *b'* inward. The ways *b² b²* on the inner surfaces of the sides *b b* form the support for the reciprocating frame *c*. The bars *c' c'*, preferably of rectangular cross section, may slide in the frame toward and from each other and terminate at their ends in rods which extend through the segmental slots *c² c²* in the rocking plates *c³ c³* and into the slots *c⁴ c⁴*, formed in the bed-plate *a* and in the end *b'*. The rocking plates *c³ c³* are pivotally supported on the studs *c⁵ c⁵*, secured in the bed-plate *a* and in the end *b'*, and are connected outside the casing by means of the bar *c⁶*, which serves to operate the rocking plates, and by means of the segmental slots *c²* to move the bars *c' c'* farther apart or nearer together.

The knives *d d* are preferably provided with wave-like corrugated cutting edges. Saw-tooth or any form of serrated cutting edges may be used. The knives *d d* are secured in oblique positions, as shown in Fig. 4, to the bars *c'* by the posts *d' d'*. When reciprocated, the knives cut the wax off the caps with a drawing cut.

On one side of the frame *c* the abutments *e e* connected with an arch are secured. The eccentric *e'* rotates between the abutments and imparts reciprocating movement to the frame *c*. The eccentric *e'* is secured to the end of the shaft *e²*, which has its bearing in one of the sides *b b*, as shown in Fig. 3. The other end of the shaft *e²* is journaled in the bracket *e³*. The balance-wheel *e⁴* is secured to the shaft and is provided with studs engaging with a slotted plate (indicated in broken lines in Fig. 1) connected with a sleeve on which the strap-pulleys *e⁵* and *e⁶* are formed or secured. The strap *e⁷* connects the strap-pulley *e⁵* with the coiled spring *e⁹*, and the strap *e⁸* connects the foot-lever *e¹⁰* with the strap pulley *e⁶*, the whole forming a well-known jig movement in which the intermittently-exerted force is transmitted to the balance-wheel and transmitted as a continuous force by the shaft *e²*.

The size of the machine is adapted to permit the passage of a conventional size of

honeycomb between the end guides $a' a'$ and between the knives $d d$.

The operation of the machine is as follows: The operator having started the machine so as to cause the knives to reciprocate pushes the bar c^6 down, which causes the knives to separate. A honeycomb is then passed between the knives until the lower edge of the wooden frame which surrounds and supports the honeycomb is below the knives. The bar c^6 is then raised until the reciprocating knives are brought in contact with the surface of the honeycomb. The honeycomb is then forced downward until the upper edge of the wooden frame is almost in contact with the knives, when the bar c^6 is again forced downward to allow the free passage of the frame, and the operation is repeated, the bar c^6 being in each instance depressed to separate the knives for the entrance and exit of the edges of the frame which supports the honeycomb.

The machine may be operated or controlled by one operator, and the uncapping can be done much more expeditiously, more cleanly, and more accurately than was heretofore possible.

Having thus described my invention, I claim as new and desire to secure by Letters Patent—

1. A device for uncapping honeycombs, having two knife-blades supported one on each side, and means for adjusting the same, whereby a honeycomb may be passed between the knives and the cells uncapped, as described.

2. In a honeycomb-uncapping device, two knife-blades extending across the two surfaces of the comb, a frame for supporting the knife-blades, means for reciprocating the frame, and mechanism for moving the knife-blades toward and away from each other, consisting of two rocking plates connected together and provided with slots in which rods formed on the ends of the knife supporting bars reciprocate, as described.

3. A honeycomb-uncapping machine, hav-

ing two knife-blades adapted to extend across the whole of the two surfaces of a comb, in combination with the adjustable supports for the knives, means for controlling the positions of the knives, and mechanism for reciprocating the knives, as described.

4. A honeycomb-uncapping machine, having two knife-blades each adapted to extend across one of the sides of a comb, irregular, preferably corrugated, cutting edges on the knives, and means for reciprocating the knives, as described.

5. In a honeycomb-uncapping machine, a frame having an opening for the passage of a honeycomb, two knives supported obliquely on the opposite sides of the frame, and means for adjusting the knives, in combination with mechanism for reciprocating the frame, where by the uncapping of the comb is facilitated, as described.

6. In a honeycomb-uncapping machine, the combination of the following instrumentalities: two knife-blades having irregular cutting edges, said knife-blades extending across the opposite sides of a honeycomb, adjustable supports for the knife-blades, mechanism for adjusting one of the knives, and mechanism for reciprocating the knives longitudinally, as described.

7. In a honeycomb-uncapping machine, the combination with the bed-plate a , the sides $b b$, ways on the sides, the frame c , the bars $c' c'$, the knife-blades $d d$, and connections between the knife-blades and the bars, of the rocking plates c^3 , the bar c^6 connecting the plates, means, comprising segmental slots, for adjusting the bars $c' c'$ and the knife-blades, and the mechanism substantially as described for reciprocating the frame c , as described.

In testimony whereof I have signed my name to this specification in the presence of two subscribing witnesses.

ARTHUR C. MILLER.

Witnesses:

J. A. MILLER, Jr.,
A. E. HAGERTY.