

No. 890,619.

PATENTED JUNE 16, 1908.

E. H. DEWEY.  
FOUNDATION FASTENER FOR HONEY SECTIONS OF BEEHIVES.

APPLICATION FILED OCT. 24, 1907.

2 SHEETS—SHEET 1.

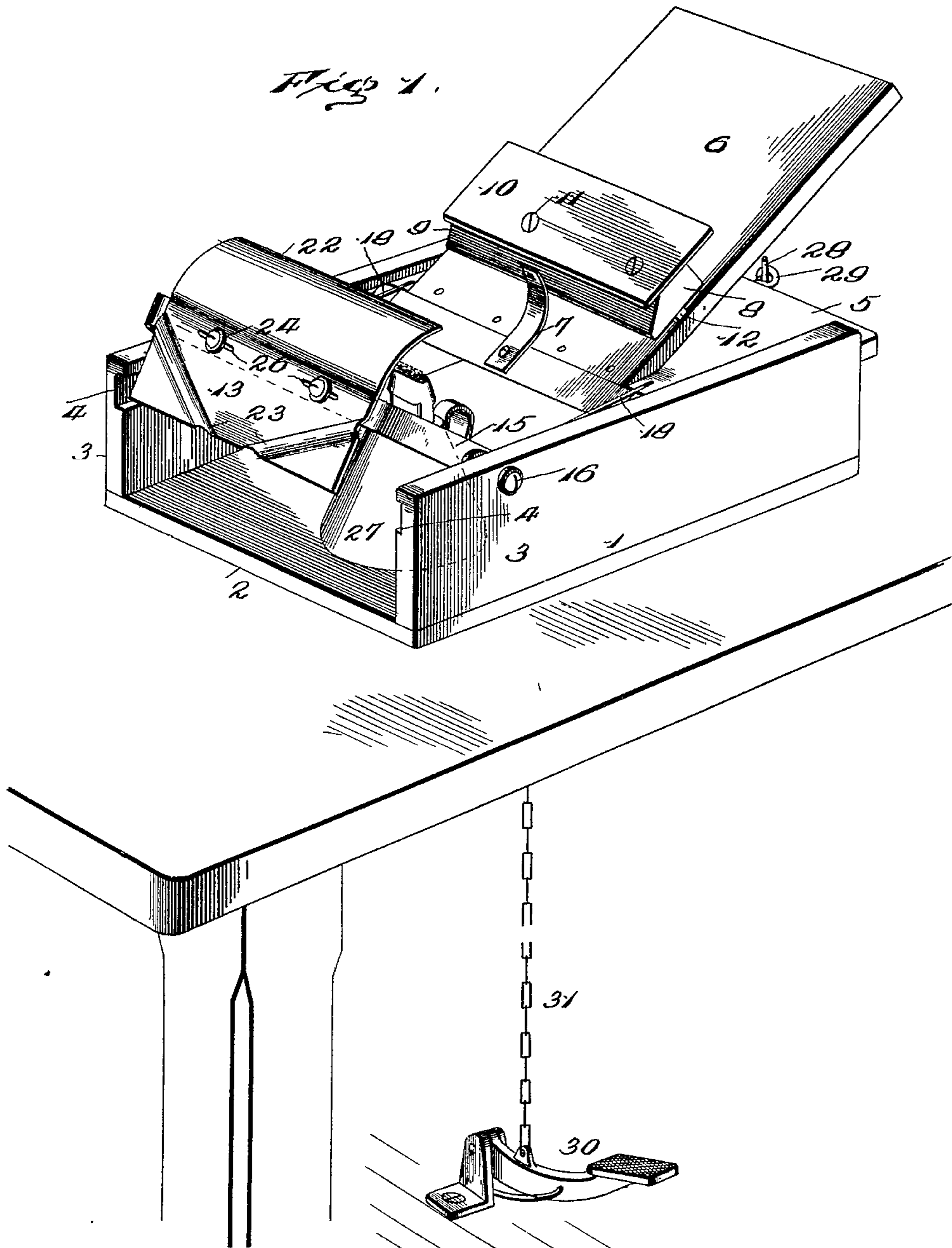

Witnesses

*H. B. Campbell*  
*L. O. Little.*

Inventor

*Elbert H. Dewey*

By

*Watson E. Coleman*

Attorney

No. 890,619.

PATENTED JUNE 16, 1908.

E. H. DEWEY.

FOUNDATION FASTENER FOR HONEY SECTIONS OF BEEHIVES.

APPLICATION FILED OCT. 24, 1907.

2 SHEETS—SHEET 2.

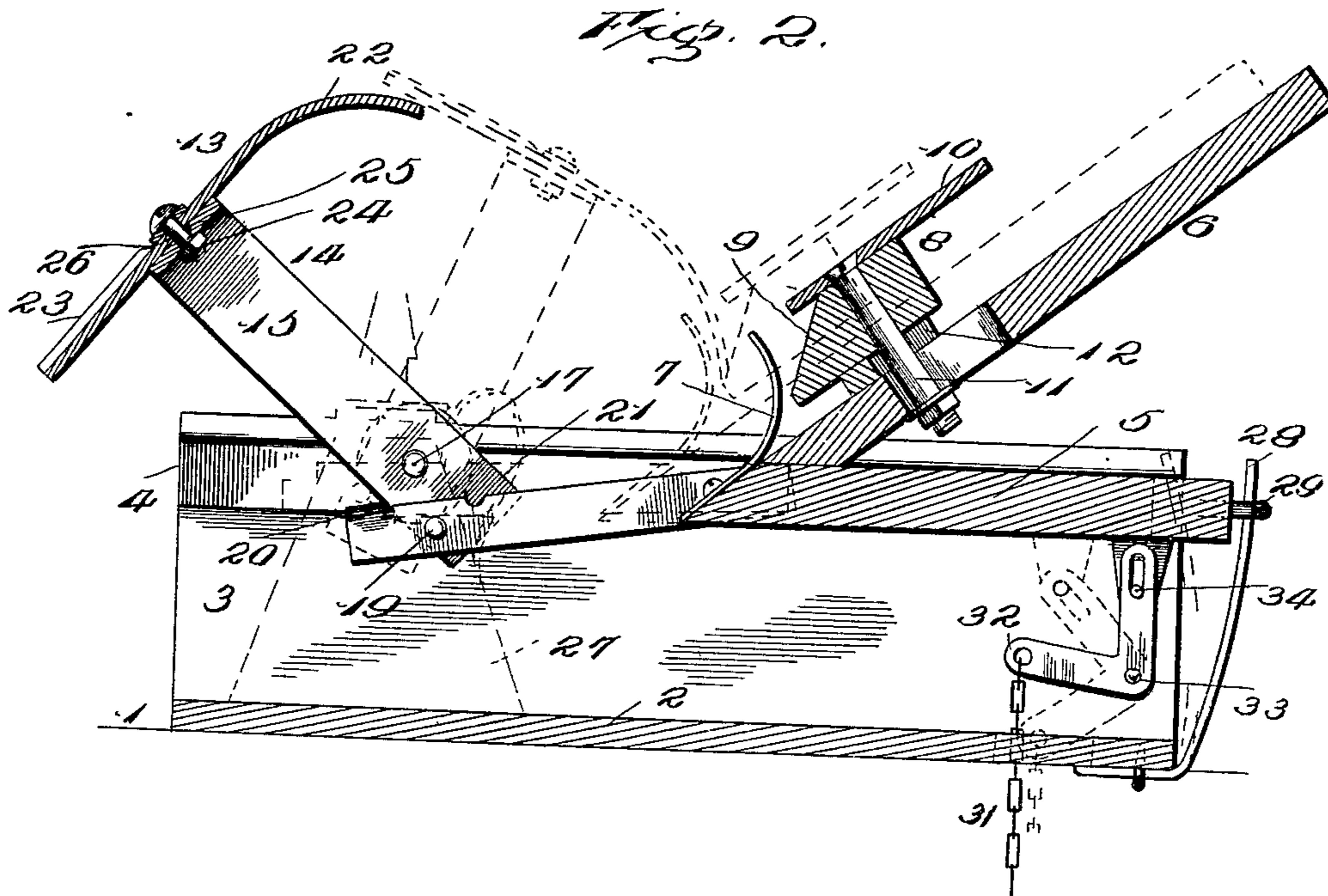

Fig. 3.

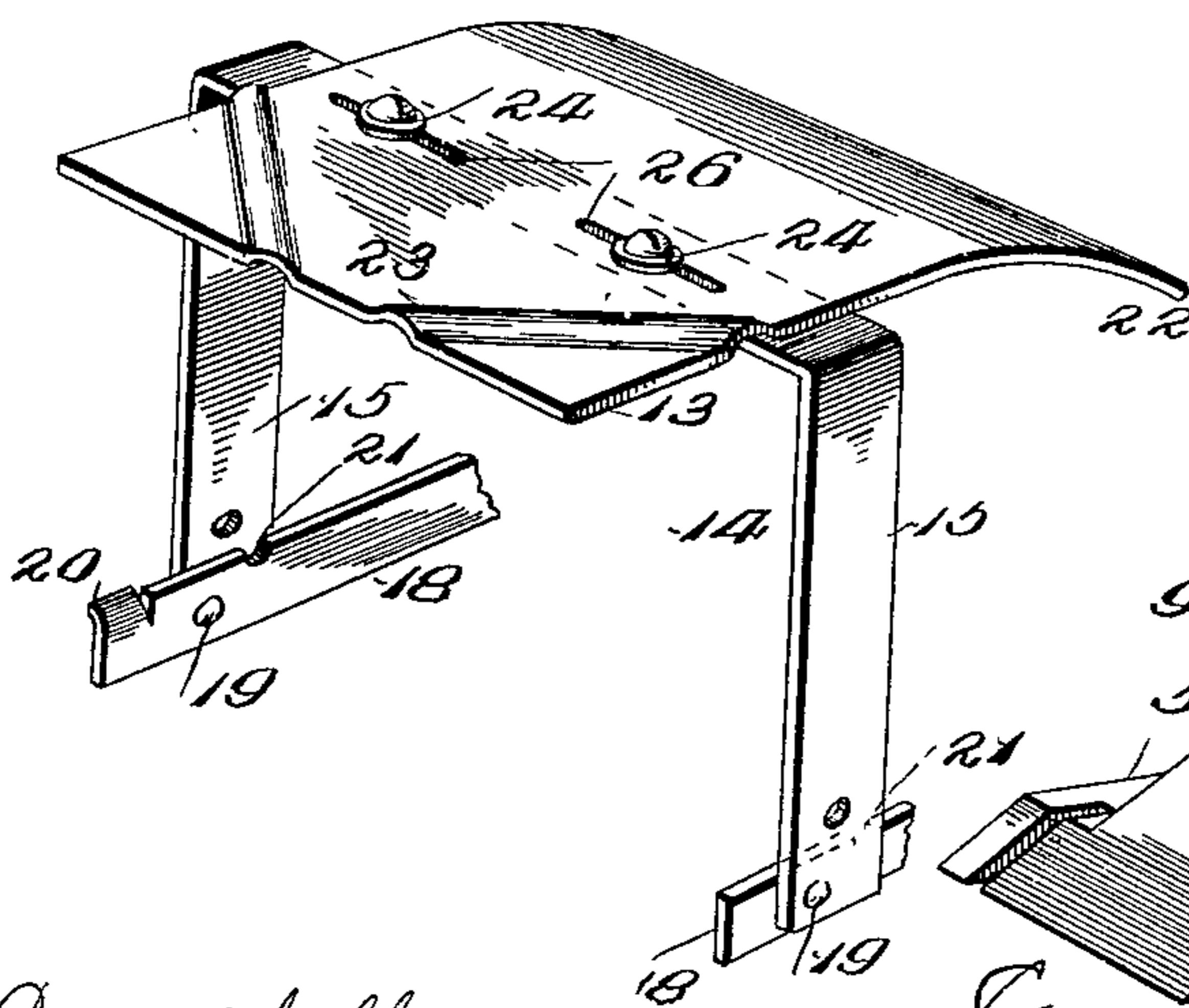
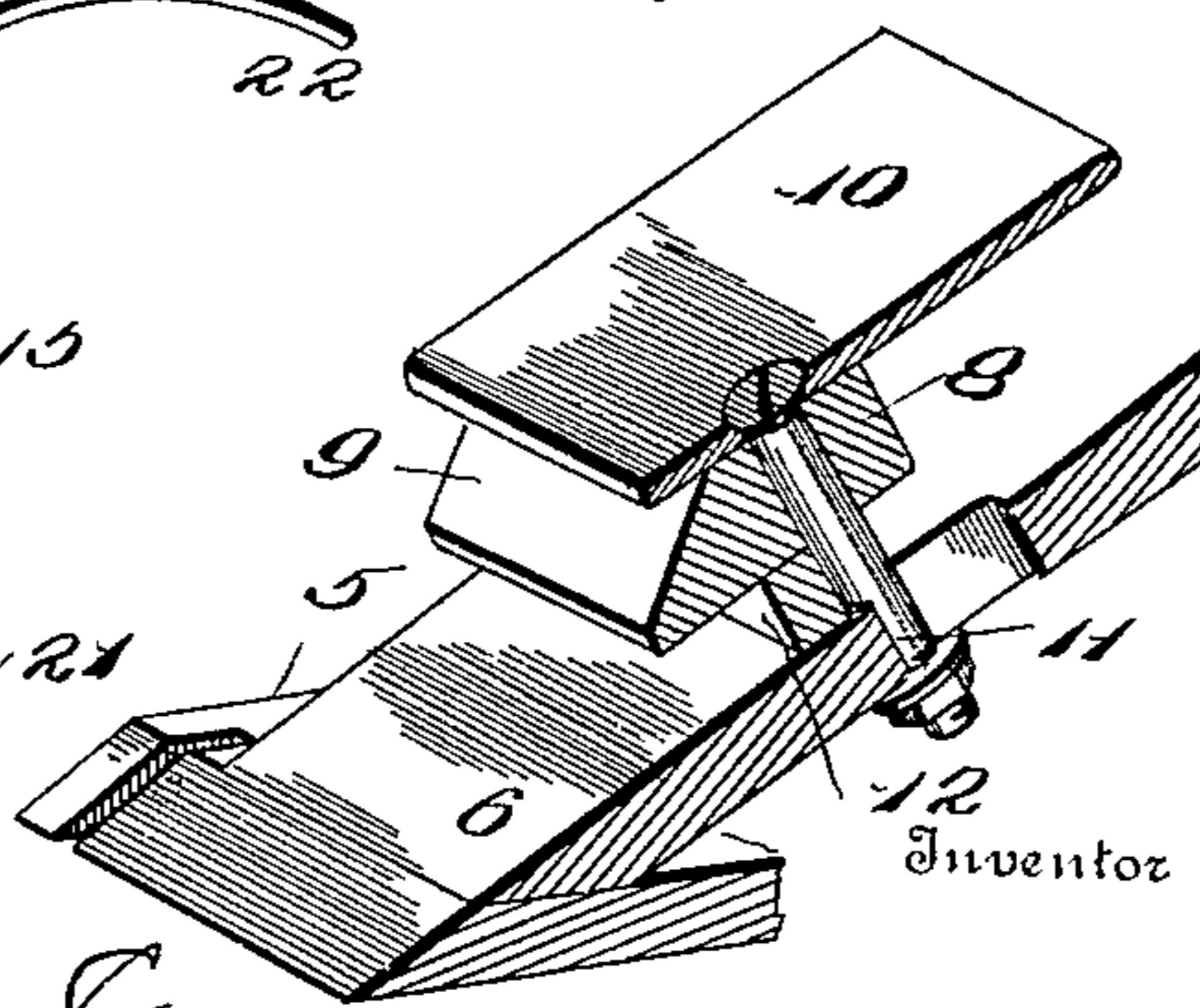

Fig. 4.



Witnesses  
 N. B. Campbell  
 L. O. Little.

By *Elbert H. Dewey*  
*Watson E. Coleman* Attorney

# UNITED STATES PATENT OFFICE.

ELBERT H. DEWEY, OF GREAT BARRINGTON, MASSACHUSETTS.

FOUNDATION FASTENER FOR HONEY-SECTIONS OF BEEHIVES.

No. 890,619.

Specification of Letters Patent.

Patented June 16, 1908.

Application filed October 24, 1907. Serial No 398,999.

*To all whom it may concern:*

Be it known that I, ELBERT H. DEWEY, a citizen of the United States, residing at Great Barrington, in the county of Berkshire and State of Massachusetts, have invented certain new and useful Improvements in Foundation Fasteners for Honey Sections of Beehives, of which the following is a specification, reference being had therein to the accompanying drawing.

My invention relates to improvements in machines or devices for attaching artificial honeycomb foundations to honey sections or frames used in beehives and it consists in the novel features of construction and the combination and arrangement of parts hereinafter described and claimed.

The object of the invention is to provide a machine of this character which will be of simple, strong, durable and comparatively inexpensive construction, which will be rapid and effective in operation and which may be readily adjusted so that the foundations may be effectively secured centrally in honey sections of any size.

Further objects and advantages of the invention, as well as the structural features by means of which these objects are attained, will be made clear by an examination of the following specification taken in connection with the accompanying drawings, in which

Figure 1 is a perspective view of my improved foundation fastener for honey sections; Fig. 2 is a vertical longitudinal section, showing the heater plate in its normally retracted position in full lines and in its projected or operative position in dotted lines; Fig. 3 is a detail perspective of the heater plate, its U-shaped lever, and one of the pivots and actuating arms of said lever; and Fig. 4 is a detail perspective of the wedge block for adjusting the foundation supporting plate.

The machine comprises a suitable base adapted to be screwed or otherwise secured to a bench, table, or other support. This base is preferably of U form consisting of a bottom 2 and two upright parallel sides 3 in the opposing faces of which adjacent to their upper edges are formed longitudinal grooves 4 adapted to receive and serve as guides for the side edges of a sliding bed plate or table 5. This movable support 5 is adapted to receive the honey section and the foundation

which is to be applied to the latter, and to this end it is provided with an upwardly and rearwardly inclined portion 6 upon which the honey section is placed. The honey section is held in position upon the bed plate or table by a curved spring 7 which presses it against a stop block 8 arranged upon the inclined portion of plate 6 and adapted to also serve as an adjustable support for the artificial foundation. This stop or gage block 8 is disposed transversely and has its forward edge beveled downwardly, as shown at 9. Upon its top is arranged a stationary plate 10 upon which the foundations are placed and which is secured to the block 8 by bolts or similar fastenings 11. These bolts pass through the block 8 and the inclined portion 6 of the support or table and are of sufficient length to permit of the adjustment of a wedge shaped block 12 between the stop or gage block 8 and the inclined portion or plate 6. It will be seen that by adjusting the wedge 12 the foundation supporting plate 10 may be supported at a greater or less distance from the inclined plate or portion 6 in order that the foundation may be positioned centrally in a honey section of any width, as will be presently explained.

The support or table 5 for the honey section is made movable or slidable to serve as an actuating means for an oscillatory heater plate 13 which is so mounted that it will swing into and out of the honey section upon said support or table as the latter is reciprocated. This heater plate is adjustably mounted upon the cross portion of a U-shaped lever 14, the parallel arms 15 of which project between the sides 3 of the base of the machine and are pivoted a suitable distance from their ends upon pivots 16 preferably in the form of bolts passed transversely through the sides 3 and adapted to have their inner ends project beyond the inner faces of the arms 15 to provide stops 17 for a purpose presently explained. The U shaped lever or frame 14 is operatively connected to the movable table or support 5 by a pair of links or arms 18. These arms have their forward ends pivoted at 19 to the lower free ends of the arms 15 of said U shaped lever and their rear ends suitably pivoted in slots or recesses in the table 5. The forward swinging movement of the lever is limited by cutting the upper edge of one of the arms or links 18 adjacent

to its forward end and bending outwardly a portion of said arm to provide a stop tongue 20 against which one of the arms 15 of the lever is adapted to strike, as clearly shown in Figs. 2 and 3; and the rearward swinging movement of said lever is limited by the engagement of the upper edges of the arms or links 18 with the stops 17 formed by the projecting ends of the pivots of the lever. If desired notches or seats 21 may be formed in said upper edges of the arms or links to receive said stops 17, as shown. The heater plate 13 has its lower end curved, as shown at 22 so that it will readily pass over the upper edge of the honey section and swing into the latter and beneath the lower edge of the foundation supporting plate 10. The rear end of said plate is formed with two converging ribs 23 which are preferably stamped in said plate, as shown, and are designed to serve as guides for directing the heated wax upon the plate into a suitable collecting receptacle (not shown). The heater plate is adjustably connected to its swinging support or lever 12 so that it may readily swing into honey sections of varying width, by passing bolts 24 through elongated apertures 25 formed in the cross portion of said lever and also through apertures 26 in the heater plate. To permit of a greater range of adjustment of said plate, the apertures 26 may also be elongated, as will be readily understood upon reference to Fig. 2.

While a heater of any description may be employed for heating the plate 13, I preferably employ an oil lamp 27 such as the one illustrated. This lamp, it will be seen, has no chimney and hence takes up little space and permits the machine to be comparatively small and compact.

The movable support or table 5 is moved in one direction, that is rearwardly, so as to hold the heater plate normally in its forward and retracted position, by means of a spring 28 or its equivalent. As shown, this spring is suitably secured upon the bottom 2 of the base and has an upwardly projecting resilient arm which passes loosely through an eye 29 arranged upon the center of the rear end of the table 5, as shown in Fig. 2. Any suitable means may be provided for moving the table in the opposite direction to cause the heater plate to be swung into the honey section, but I preferably employ a treadle 30 which is suitably hinged or pivoted to the floor or a support thereon and is connected by a chain or the like 31 to a bell crank 32 arranged in the base 1 and pivoted at 33 upon one of the sides 3. A suitable aperture is provided in the bottom 2 of the base for the upper end of the chain which end is attached to the bell crank. The other arm of the latter is connected by a link 34 to the table 5, as clearly shown in Fig. 2.

The operation of the machine is as follows.

Assuming the parts to be properly adjusted and in their normal position shown in full lines in the drawings, a honey section is placed upon the inclined portion 6 of the table or support 5 so that one of its sides is pressed by the spring 7 against the stop block 8. The treadle is then depressed so that the bell crank 33 will be actuated to move the table 5 forwardly. This movement of the table causes the lever 14 to be swung upon its pivot and to move the curved edge 22 of the heater plate 13 in an arcuate path and into the honey section and beneath the lower edge of the foundation supporting plate 10. An artificial honeycomb foundation is then dropped upon the plate 10 and allowed to slide downwardly or is pushed downwardly against the heater plate and when the edge of foundation in contact with the latter has melted, the pressure on the treadle is relieved so that the spring 28 may restore the parts to their normal positions. As the heater plate recedes from the honey section the foundation will drop into contact with said section and will adhere to the same, as will be readily understood. The honey section and its attached foundation may then be removed and the above described operation repeated. To adjust the device for honey sections of different widths it is only necessary to loosen the bolts 11 and adjust the wedge 12 beneath the block 8. The engagement of the links 18 with the stops 17 limits the forward swinging movement of the lever 14 and by reason of the adjustment of the heater plate upon said lever the curved rear edge of said plate may be caused to stop just before it contacts with the beveled edge of the block 8. This adjustment is essential to the efficient working of the machine and may be readily effected by loosening the bolts 24 and shifting the plate 13 upon the lever.

Having thus described my invention what I claim and desire to secure by Letters Patent is:

1. In a foundation fastener for honey sections, means for supporting a honey section and a heater plate mounted for swinging movement in an arcuate path and movable into and out of a honey section upon said supporting means.

2. In a foundation fastener for honey sections, means for supporting a honey section, a lever, a heater plate carried by said lever and adapted to be swung into and out of a honey section upon said supporting means and means for operating said lever.

3. In a foundation fastener for honey sections, means for supporting a honey section, a lever, a heater plate carried by said lever and movable into and out of a honey section upon said supporting means and means for adjusting said heater plate upon said lever.

4. In a foundation fastener for honey sections, means for supporting a honey section,

- a lever, a heater plate carried thereby and adapted to be swung into and out of a honey section upon said supporting means, means for operating said lever and a stop for limiting the swinging movement of said lever. 5
5. In a foundation fastener for honey sections, means for supporting a honey section, a U-shaped lever having its arms pivotally mounted and a heater plate carried by the cross portion of said lever and movable into and out of a honey section upon said supporting means. 10
6. In a foundation fastener for honey sections, means for supporting a honey section, and a heater plate mounted for swinging movement and having a curved portion to be moved into and out of a honey section upon said supporting means. 15
7. In a foundation fastener for honey sections, means for supporting a honey section, a heater plate mounted for swinging movement and movable into and out of a honey section upon said supporting means, and means for limiting the movement of said heater plate in said honey section. 20
8. In a foundation fastener for honey sections, means for supporting a honey section, a heater plate movable into and out of a honey section upon said supporting means, and means upon said heater plate for directing melted wax into a suitable receptacle. 25
9. In a foundation fastener for honey sections, means for supporting a honey section, a heater plate movable into and out of a honey section upon said supporting means and inclined guide ribs upon said plate for directing melted wax towards one of its ends. 30
10. In a foundation fastener for honey sections, a support for a honey section, a stop upon said support, resilient means for holding a honey section against said stop and a heater plate movable into and out of a honey section upon said support. 35
11. In a foundation fastener for honey sections, a support for a honey section, a stop upon said support, a leaf spring for pressing a honey section against the stop on said support and a heater plate movable into and out of the honey section. 40
12. In a foundation fastener for honey sections, a support for a honey section, a foundation supporting member arranged upon said support, a wedge arranged between said member and said support, adjustable fastenings connecting said member and said support and a heater plate to enter the honey section upon said support. 45
13. In a foundation fastener for honey sections, a support, for a honey section, a block upon said support, a wedge between said block and said support, a foundation supporting plate upon said block, adjustable fastenings connecting said block to said support, and a heater plate to enter the honey section upon said support. 50
14. In a foundation fastener for honey sections, a support for a honey section, a block upon said support, a wedge between said block and said support, a foundation supporting plate upon said block, adjustable fastenings connecting said block to said support, a spring for pressing a honey section against said block and retaining it upon said support and a heater plate movable into said honey section. 55
15. In a foundation fastener for honey sections, a base, a movable table thereon for supporting a honey section, and a heater plate mounted for swinging movement upon said base and operatively connected to said table for simultaneous movement therewith. 60
16. In a foundation for honey sections, a base, a slidable table thereon for supporting a honey section, a heater plate mounted for swinging movement upon said base and movable into and out of the section upon said table, and means connecting said heater plate and said sliding table for simultaneous movement. 65
17. In a foundation fastener for honey sections, a base, a movable table thereon for supporting a honey section, a lever, a heater plate carried thereby and an operative connection between said lever and said table. 70
18. In a foundation fastener for honey sections, a base, a sliding table thereon for supporting a honey section, a lever pivoted upon said base, a heater plate carried by said lever, a link connecting said lever and said table and means for limiting the swinging movement of said lever. 75
19. In a foundation fastener for honey sections, a base, a movable table thereon for supporting a honey section, a lever carrying a heater plate, means connecting said lever and said table for simultaneous movement, and a stop for limiting the swinging movement of said lever in one direction. 80
20. In a foundation fastener for honey sections, a base, a movable table thereon for supporting a honey section, a lever carrying a heater plate, means for connecting said lever and said table for simultaneous movement and stops for limiting the swinging movement of said lever in both directions. 85
21. In a foundation fastener for honey sections, a base, a movable table thereon for supporting a honey section, a lever carrying a heater plate, a pivot for said lever carried by said base and provided with a stop, and a link connecting said lever and said table for simultaneous movement and adapted to engage the stop formed by said pivot to limit the swinging movement of the lever in one direction. 90
22. In a foundation fastener for honey sections, a base, a movable table thereon for sup- 95

porting a honey section, a lever carrying a heater plate, a link connecting said lever and said table for simultaneous movement and a stop carried by said link to engage said lever and limit its movement in one direction.

23. In a foundation fastener for honey sections, a base, a movable table thereon for supporting a honey section, a lever carrying a heater plate, a pivot for the lever carried by said base and having a projection to form a stop, a link connecting said lever and said table and adapted to engage the stop formed by said pivot to limit the movement of the lever in one direction, and a stop upon said link adapted to engage the lever to limit its movement in the opposite direction.

24. In a foundation fastener for honey sections, a base having guides, a table slidable in said guides, means upon said table for supporting a honey section and a foundation, a U shaped lever pivoted upon said support, links connecting said lever to said table, and a heater plate carried by said lever and adapted to be swung into and out of a honey section upon said table.

25. In a foundation fastener for honey sections, a base having guides, a table slidable in said guides, means upon said table for supporting a honey section and a foundation, a

U shaped lever pivoted upon said support, links connecting said lever to said table, a heater plate carried by said lever and movable into and out of a honey section upon said table and means for reciprocating said table.

26. In a foundation fastener for honey sections, a base, a table slidable thereon for supporting a honey section, a lever upon said base and operatively connected to said table, a heater plate carried by said lever, a spring for moving said table in one direction and means for moving said table in the opposite direction.

27. In a foundation fastener for honey sections, a base, a table slidable thereon for supporting a honey section, a lever upon said base and operatively connected to said table, a heater plate carried by said lever, a spring for moving said table in one direction, a bell crank upon said base and operatively connected to said table, a treadle and a flexible connection between said treadle and said bell crank.

In testimony whereof I hereunto affix my signature in presence of two witnesses.

ELBERT H. DEWEY.

Witnesses:

H. W. SCOTT,

T. J. McDERMOTT.