

G. W. BACON.
 BROOD FRAME FOR BEEHIVES.
 APPLICATION FILED JULY 23, 1915.

1,184,506.

Patented May 23, 1916.

Fig. 1.

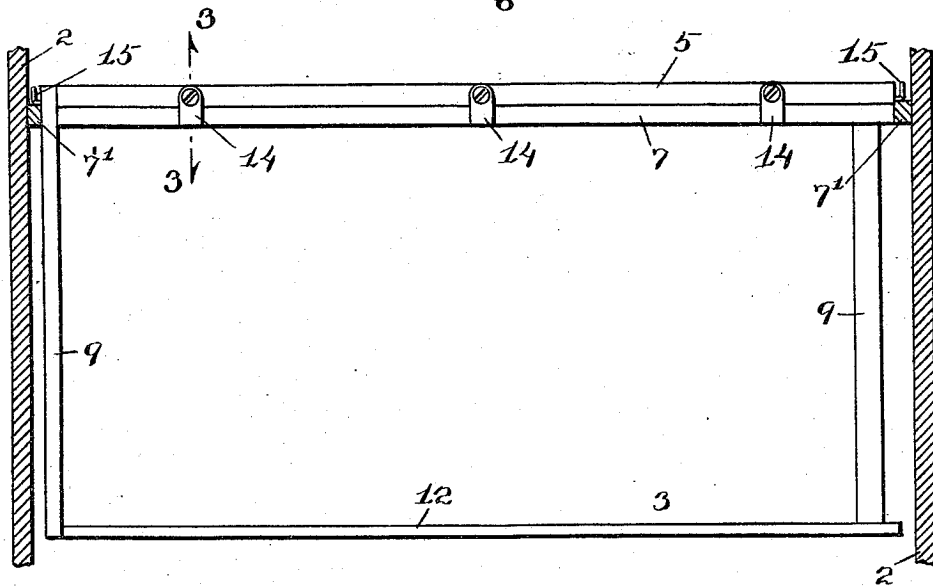

Fig. 2.

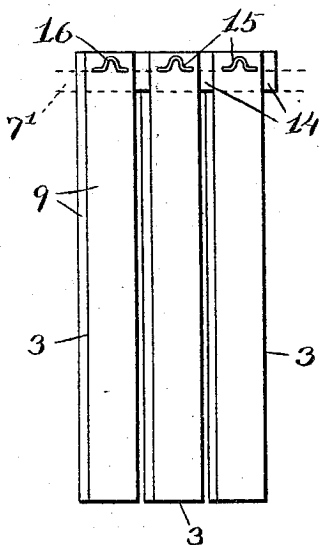

Fig. 3.

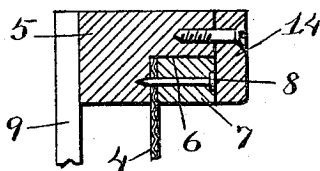
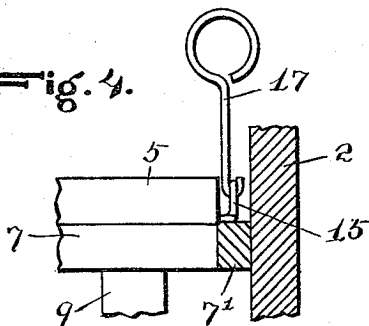

Fig. 4.



Witness
Stuart Hilder.

By

Inventor
George W. Bacon
E. W. Anderson
 Attorneys

UNITED STATES PATENT OFFICE.

GEORGE W. BACON, OF GRAND JUNCTION, COLORADO.

BROOD-FRAME FOR BEEHIVES.

1,184,506.

Specification of Letters Patent.

Patented May 23, 1916.

Application filed July 23, 1915. Serial No. 41,548.

To all whom it may concern:

Be it known that I, GEORGE W. BACON, a citizen of the United States, resident of Grand Junction, in the county of Mesa and State of Colorado, have made a certain new and useful Invention in Brood-Frames for Beehives; and I declare the following to be a full, clear, and exact description of the same, such as will enable others skilled in the art to which it appertains to make and use the invention, reference being had to the accompanying drawings, and to letters or figures of reference marked thereon, which form a part of this specification.

Figure 1 is a front view of the invention as applied showing the hive. Fig. 2 is an end view of several brood frames having my invention applied thereto, the supporting strip of the hive being shown in dotted lines. Fig. 3 is a section on the line 3—3, Fig. 1. Fig. 4 is a fragmentary side view partly in section, showing one of the wire hooks in engagement with a staple form device.

The object of the invention is to provide an improvement in brood frames for beehives, designed to simplify their structure and facilitate their operation, and it consists in the novel construction and combination of parts, as hereinafter set forth.

In the accompanying drawings, the numeral 2, designates the outer frame or casing of a hive, and 3, a brood-frame designed to be located therein, and removable therefrom. Each brood-frame is rectangular in form and is provided with a rectangular sheet of wax 4, which is impressed with a hexagonal conformation, such as is commonly used in providing foundation sheets or "foundations", as they are called. These foundations are used by the bees in their work of forming the wax comb, and in order to provide for the proper attachment of the wax sheet in the frame, and to secure certain advantages of operation of the brood-frame, the upper bar 5, of the frame, is made with a right angle seat 6, extending along its bottom and side, this channel being provided with a rectangular strip 7, designed, when secured in the seat 6, to press upon the edge of a wax foundation sheet located between the edge of the channel and the side of the strip.

After the strip is placed upon the edge of the wax sheet, it is connected thereto and to the bar 5, through suitable perforations therein, by small tacks or headed pins 8.

Usually one of these headed pins is driven through the wax sheet near each end, and if the frame be large, a third pin is used in the middle of the frame. The end bars 9, and the lower or bottom bar 12, of the frame, are of usual form, as is in fact the upper bar, except that it is modified to avoid undue pressure, and to operate in connection with offset devices, whereby the brood frames are designed to be easily and exactly located in the casing and relatively placed with the accuracy required; and whereby the removal or reintroduction of a brood frame is readily effected in the vertical plane.

The strip 7 is not designed to be forcibly pressed against the side of the channel or seat 6, in such wise as to mash or break the edge of the wax sheet; but is of sufficient thickness to engage the surface of the wax closely, and when the headed pins 8 are secured in place the wax sheet is held securely. In this connection the tacks and strip are prevented from becoming loose by means of thick buttons 14, which are pivoted to the side of the bar 5 by suitable screws and, when in pendant or turned down position, engage the heads of the pins 8, which are located below the pivot screws of the buttons, and hold the pins and strip in position. These buttons are designed also to serve as braces or interposed means for keeping the brood-frames the proper distance apart. This distance is one-quarter of an inch, and the buttons of each frame are made with that thickness, and parallel-faced, and are designed each to be long enough to extend from its pivotal point in the bar 5 to engage the strip 7, but not below the bottom of the latter. In this way each brood-frame is separated from the adjacent one, the frame at one end of the hive being separated from the casing by a special offset or projection attached to the latter. The ends of the frame are also provided with hanger offsets projecting a fraction of an inch and engaging supporting strips 7' of a width of about one-quarter of an inch, in order to separate the frames from the walls of the hive, these offsets being horizontal staple-form devices 15, the prongs of which are seated in the broad part of the bar 5 and in the ends thereof. These staples extend transversely of the ends of the bars 5, and each one is made with an upturned loop or bend exactly in the middle of its transverse bar, which is accurately placed in the driving so

UNITED STATES PATENT OFFICE.

GEORGE W. BACON, OF GRAND JUNCTION, COLORADO.

BROOD-FRAME FOR BEEHIVES.

1,184,506.

Specification of Letters Patent.

Patented May 23, 1916.

Application filed July 23, 1915. Serial No. 41,548.

To all whom it may concern:

Be it known that I, GEORGE W. BACON, a citizen of the United States, resident of Grand Junction, in the county of Mesa and State of Colorado, have made a certain new and useful Invention in Brood-Frames for Beehives; and I declare the following to be a full, clear, and exact description of the same, such as will enable others skilled in the art to which it appertains to make and use the invention, reference being had to the accompanying drawings, and to letters or figures of reference marked thereon, which form a part of this specification.

Figure 1 is a front view of the invention as applied showing the hive. Fig. 2 is an end view of several brood frames having my invention applied thereto, the supporting strip of the hive being shown in dotted lines. Fig. 3 is a section on the line 3—3, Fig. 1. Fig. 4 is a fragmentary side view partly in section, showing one of the wire hooks in engagement with a staple form device.

The object of the invention is to provide an improvement in brood frames for beehives, designed to simplify their structure and facilitate their operation, and it consists in the novel construction and combination of parts, as hereinafter set forth.

In the accompanying drawings, the numeral 2, designates the outer frame or casing of a hive, and 3, a brood-frame designed to be located therein, and removable therefrom. Each brood-frame is rectangular in form and is provided with a rectangular sheet of wax 4, which is impressed with a hexagonal conformation, such as is commonly used in providing foundation sheets or "foundations", as they are called. These foundations are used by the bees in their work of forming the wax comb, and in order to provide for the proper attachment of the wax sheet in the frame, and to secure certain advantages of operation of the brood-frame, the upper bar 5, of the frame, is made with a right angle seat 6, extending along its bottom and side, this channel being provided with a rectangular strip 7, designed, when secured in the seat 6, to press upon the edge of a wax foundation sheet located between the edge of the channel and the side of the strip.

After the strip is placed upon the edge of the wax sheet, it is connected thereto and to the bar 5, through suitable perforations therein, by small tacks or headed pins 8.

Usually one of these headed pins is driven through the wax sheet near each end, and if the frame be large, a third pin is used in the middle of the frame. The end bars 9, and the lower or bottom bar 12, of the frame, are of usual form, as is in fact the upper bar, except that it is modified to avoid undue pressure, and to operate in connection with offset devices, whereby the brood frames are designed to be easily and exactly located in the casing and relatively placed with the accuracy required; and whereby the removal or reintroduction of a brood frame is readily effected in the vertical plane.

The strip 7 is not designed to be forcibly pressed against the side of the channel or seat 6, in such wise as to mash or break the edge of the wax sheet; but is of sufficient thickness to engage the surface of the wax closely, and when the headed pins 8 are secured in place the wax sheet is held securely. In this connection the tacks and strip are prevented from becoming loose by means of thick buttons 14, which are pivoted to the side of the bar 5 by suitable screws and, when in pendant or turned down position, engage the heads of the pins 8, which are located below the pivot screws of the buttons, and hold the pins and strip in position. These buttons are designed also to serve as braces or interposed means for keeping the brood-frames the proper distance apart. This distance is one-quarter of an inch, and the buttons of each frame are made with that thickness, and parallel-faced, and are designed each to be long enough to extend from its pivotal point in the bar 5 to engage the strip 7, but not below the bottom of the latter. In this way each brood-frame is separated from the adjacent one, the frame at one end of the hive being separated from the casing by a special offset or projection attached to the latter. The ends of the frame are also provided with hanger offsets projecting a fraction of an inch and engaging supporting strips 7' of a width of about one-quarter of an inch, in order to separate the frames from the walls of the hive, these offsets being horizontal staple-form devices 15, the prongs of which are seated in the broad part of the bar 5 and in the ends thereof. These staples extend transversely of the ends of the bars 5, and each one is made with an upturned loop or bend exactly in the middle of its transverse bar, which is accurately placed in the driving so