

E. E. RUSSELL & W. C. CUTLER.  
 HONEYCOMB.  
 APPLICATION FILED MAR. 26, 1917.

1,238,343.

Patented Aug. 28, 1917.

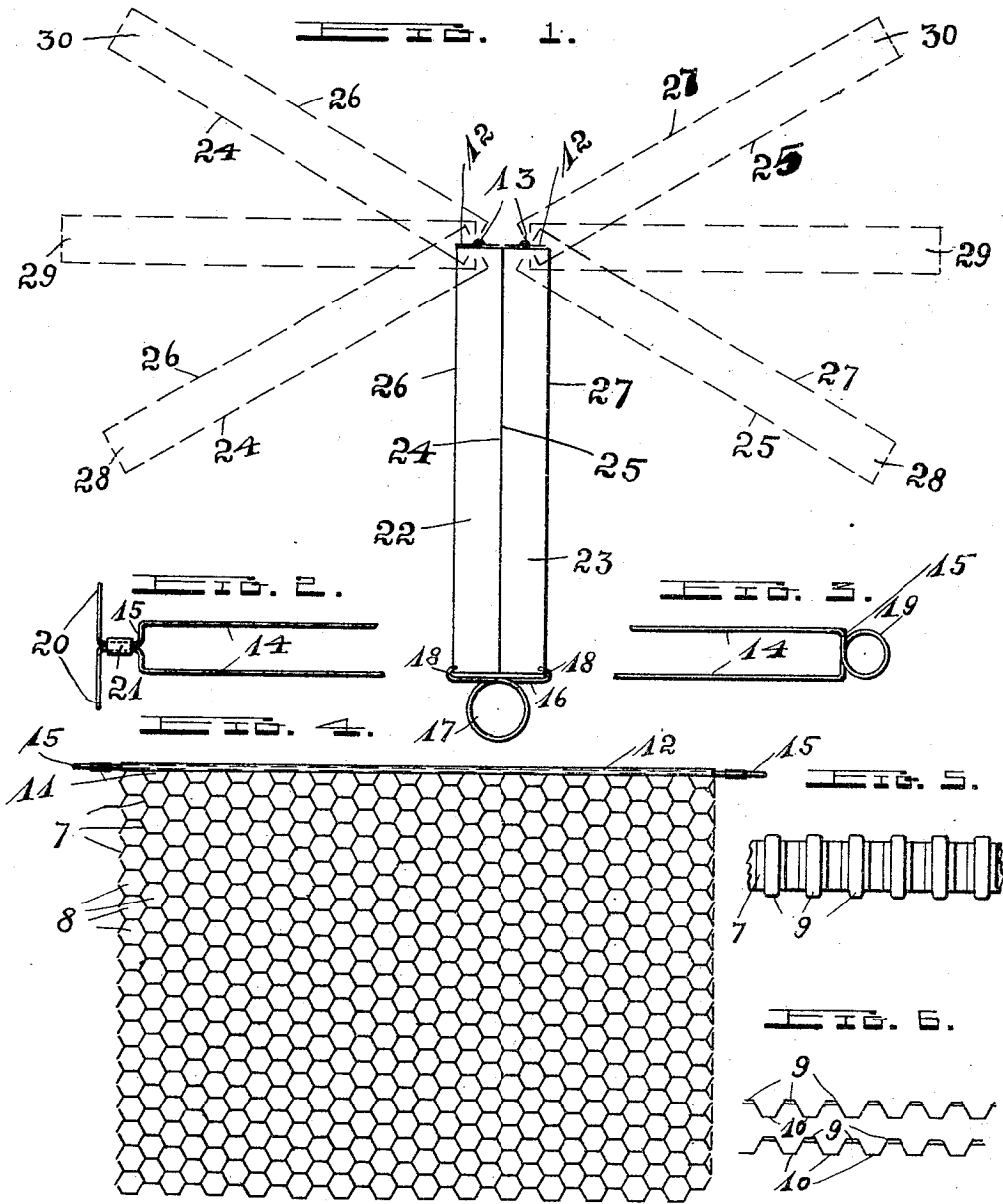

WITNESSES:  
 Evelyn N. Sparks  
 Lucian Gray

INVENTOR  
 Edward E. Russell  
 William C. Cutler  
 BY

ATTORNEY

# UNITED STATES PATENT OFFICE.

EDWARD E. RUSSELL, OF LOS ANGELES, AND WILLIAM C. CUTLER, OF NORTH  
GLENDALE, CALIFORNIA.

## HONEYCOMB.

1,238,343.

Specification of Letters Patent. Patented Aug. 28, 1917.

Application filed March 26, 1917. Serial No. 157,533.

*To all whom it may concern:*

Be it known that we, EDWARD E. RUSSELL and WILLIAM C. CUTLER, citizens of the United States, residing, respectively, at Los Angeles, in the county of Los Angeles and State of California, and at North Glendale, in the county of Los Angeles and State of California, have invented a new and useful Honeycomb, of which the following is a specification.

Our invention relates to devices to substitute the honey-combs usually built up by bees in hives, and the main object of this invention is to provide a substitute which can easily be inserted into the hives and will readily be taken by the bees.

Another object is to provide a double comb, the two members being swingably connected by a link which allows the two members to swing in such a way as to bring the opposite sides of each comb member alternately to the front for the bees to enter.

Another object is to provide clamping members by which the two comb members can be held together in their alternative positions.

Another object is to make the comb out of sheet material of such design which can be interlocked so as to incorporate the several corrugated and stamped sheets into a comb.

Other objects will appear in the following description and claims, and in the accompanying drawing, in which—

Figure 1 is an end view of our device.

Fig. 2 is a side view of our device.

Fig. 3 is a detail plan view of the connecting link in our device.

Fig. 4 is a detail plan view of a modified link for our device.

Fig. 5 is a detail fragmental plan view of the strips making up the comb.

Fig. 6 is a detail fragmental side view of the strips making up the comb.

Referring to the drawing, 7 designates the strips stamped and pressed to form the small hexagonal compartments 8, see Fig. 4. In Figs. 5 and 6 these strips are shown in detail being provided with the lips 9 to fit and engage over the edges 10 of the next strip in the comb, as will be best understood from the illustration in Fig. 6, the lips 9 being bent and clamped over the edges 10 to hold the whole comb together as one piece, as shown in Fig. 4. The strips are made of

thin material, like sheet iron, aluminum or other suitable material. The upper strip 11 is interconnected with the top plate 12 in the same manner as the several strips are interconnected as described above. The top plate forms at the same time the sheath for the link connection between the two combs, as shown in Fig. 1. Into the sheath-like recess 13 of the end plate 12 fit the fork-like members 14 of the link 15 holding the one edge of two combs together while the opposite edges of the two combs are held together by the clamping members 16, formed by coil spring members 17 and the hooks 18.

The modified form of link 15 illustrated in Fig. 3 is also formed by a coiled spring member 19 ending in the two fork-like members 15, while the link, illustrated in Fig. 2, is formed by the squarely bent members ending in the handles 20 at one end and forming the fork-like members at the other end. Two of such squarely bent members are held together by the sleeve 21.

In using this type of comb, a piece of paraffin paper is placed between the two combs 22 and 23 when the two sides 24 and 25 are folded together leaving the sides 26 and 27 free for the bees to enter into the small hexagonal compartments or cells to carry in and deposit their honey, without having to build a comb of wax, as they usually do. Before these combs are placed into the hives, they are dipped into wax to make them appear like other honeycombs.

After the combs have been filled with honey, the clamping members 16 are taken off, and the combs are separated and unfolded in the direction indicated at 28 in Fig. 1, and, after having poured out the honey, the combs are simply folded over further past the straight line indicated at 29 and further as indicated at 30 to finally bring the sides 26 and 27 together, while the sides 24 and 25 are then facing the outside of the double comb, ready for the bees to enter and deposit their honey.

As the bees close up the cells when filled with honey, this closed side is always turned inside forming the partition between the two combs which was first formed by the sheet of paraffin disposed between the two combs, and after both sides have been closed by the bees, one side has naturally to be opened which is simply done by scratching

the wax from the first built up sides, while the newly closed sides are folded toward each other.

By constructing the combs in this way, it allows a folding toward either side, honey to be taken out each time when opened and refolded.

The bees naturally will carry honey instead of having to build a new comb, and, in case that foul brood collects in the cells, the whole comb is simply dipped into hot water whereby the wax and everything else in the cells is washed out. Then the comb is again dipped into a new wax fluid and is thereby made ready for a new filling, as described above.

Having thus described our invention, we claim:

1. In a honey comb of the class described a suitable number of strips corrugated crosswise to conform with the shape of the cells made by the bees having lugs on the longitudinal edges of suitable length and width to engage over the edges of the adjoining strips interconnecting the several strips into one comb with cells similar to the cells made by bees.

2. In a honey comb of the class described a suitable number of strips corrugated crosswise having lugs on the longitudinal edges of the strips on every fourth bend in the corrugation on each side of the strips, substantially as and for the purpose described.

3. A honeycomb of the type described comprising a suitable number of strips having means for interconnecting the several strips into one honeycomb, a plate longitudinally recessed along its middle secured to one side of the comb with the recess toward the side of the comb, and a link connection fitting in the recess of the secured plate formed to connect two combs alternately and swingably with the two opposite faces together.

4. A honeycomb of the type described comprising a suitable number of strips hav-

ing means for interlocking the several strips into one honeycomb, a link connection having means adapted to hold two combs alternately folded toward each other, and a clamping spring member for holding the two combs in such alternative position.

5. A honeycomb of the type described comprising a suitable number of strips having means for interlocking the several strips into one honeycomb, the strips being stamped and pressed to form such interlocking means along the longitudinal edges and to form corrugated surfaces which form the cells between the several strips when so interlocked into a honeycomb.

6. In a honey comb of the type described the combination with two combs swingably connected so as to allow the folding of the combs bringing two of the four open faces alternately together of a coil spring member terminating in hooks of suitable size to engage over the outer faces of the two combs into the nearest cell for holding the two combs in this connected position.

7. In a honey comb of the type described in combination with two comb members having suitably stamped and pressed strips secured along one side of each comb member forming a recess along the middle between the strips and the side of the comb members, spring wires formed to terminate in substantially parallel ends for engaging with the recess on the comb members so as to form the link connection between the two comb members allowing a folding of the two comb members so as to bring two of the four faces of the two comb members alternately together.

In testimony whereof we hereunto affix our signatures in the presence of two witnesses.

EDWARD E. RUSSELL.  
WILLIAM C. CUTLER.

Witnesses:

EVALYN N. SPARKS,  
LUCIEN GRAY.