

1,242,628.

Patented Oct. 9, 1917.

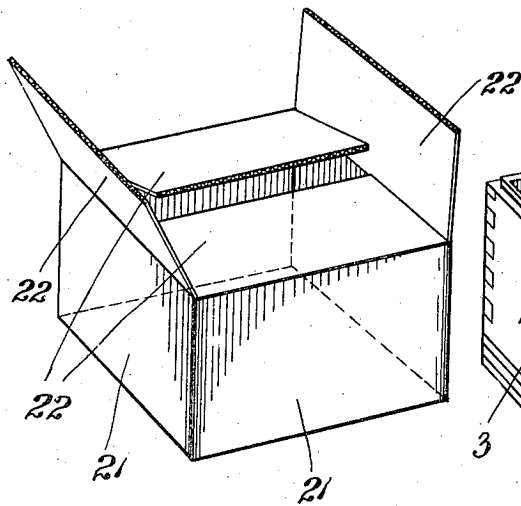

Fig. 5.

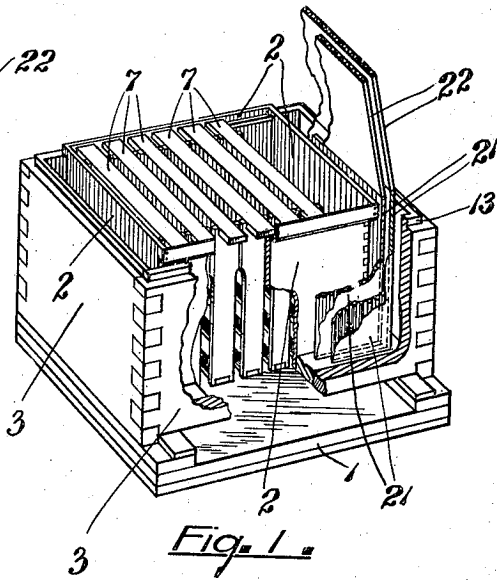

Fig. 1.

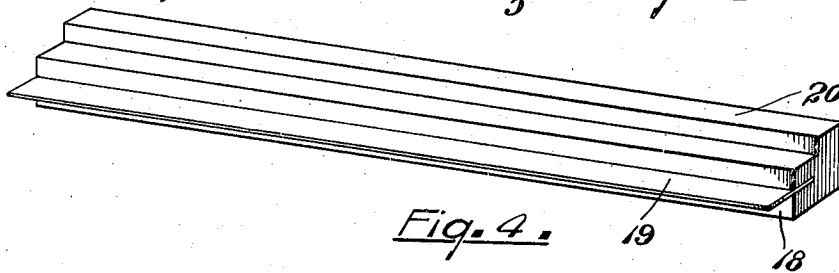

Fig. 4.

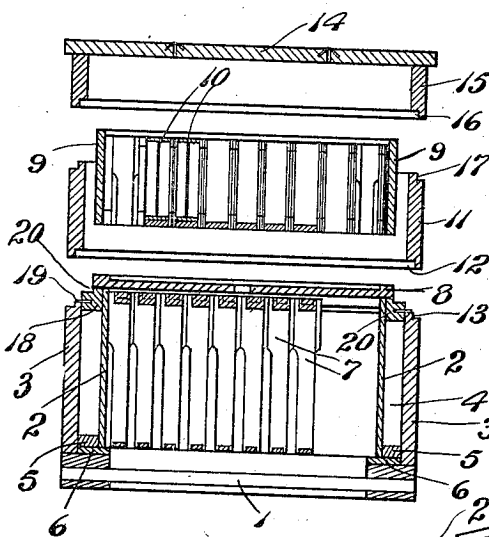

Fig. 3.

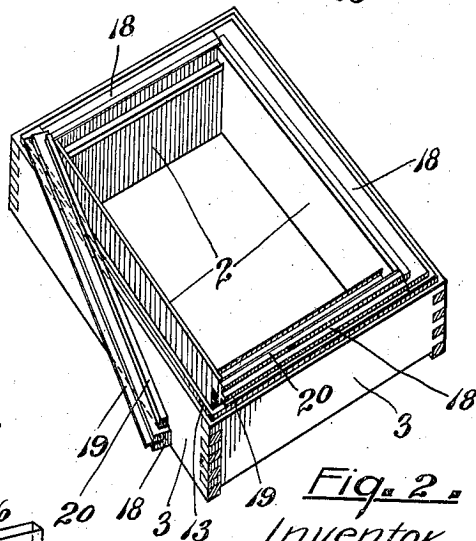

Fig. 2.

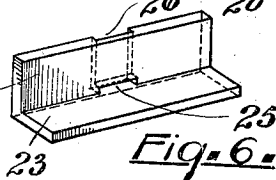

Fig. 6.

Inventor
Albert G. Woodman
By Moulton & Linnane
Attorneys.

UNITED STATES PATENT OFFICE.

ALBERT G. WOODMAN, OF GRAND RAPIDS, MICHIGAN.

BEEHIVE.

1,242,628.

Specification of Letters Patent.

Patented Oct. 9, 1917.

Application filed January 26, 1916. Serial No. 74,391.

To all whom it may concern:

Be it known that I, ALBERT G. WOODMAN, a citizen of the United States of America, residing at Grand Rapids, in the county of Kent and State of Michigan, have invented certain new and useful Improvements in Beehives; and I do hereby declare the following to be a full, clear, and exact description of the invention, such as will enable others skilled in the art to which it appertains to make and use the same.

This invention relates to a hive for bees and it is the object and purpose, primarily, of the invention, to provide a hive construction by means of which bees in the hive may be protected against severe weather especially such as occurs in winter time. The invention comprises various constructions and arrangements of parts such that this protection may be readily afforded and at the same time no complicated or involved construction be needed. For an understanding of the construction of the hive by means of which this end is attained, reference may be had to the accompanying drawing, in which:

Figure 1 is a perspective view with parts broken away and shown in section of the hive body illustrating the means used to protect the swarm in winter weather.

Fig. 2 is a perspective view of the hive body, the frames being removed therefrom and showing the removable strips used during the working season or during warmer weather.

Fig. 3 is a transverse section taken through the parts of a complete hive, these parts being separated and located one above the other for a clearer showing of the construction.

Fig. 4 is a perspective view of one of the strips used to cover the dead air space between the separated parts of the hive body;

Fig. 5 is a perspective view of a corrugated paper box of conventional structure one or more of these boxes being used to help house the swarm in the hive body during winter weather, one box telescoping into another when more than one is used; and

Fig. 6 is a perspective view of an entrance member to the hive.

Like reference characters refer to like parts throughout the several views of the drawing.

In the construction of the hive a base 1 is provided, this being separable from the

hive body and reversible, the hive body being positioned above this base and consisting of inner and outer open ended rectangular parts having sides 2 and 3, sides 2 of the inner part being located within the sides 3 of the outer part and spaced a distance therefrom to make a dead air space 4 between all of the sides or walls 2 and 3. Adjacent the lower edges the sides 2 and 3 are connected by bars as 5 shown in Fig. 3 so that the inner and outer members are inseparably connected together. These bars 5 are located above and rest upon lower bars 6 on the base. The inner part of the hive body carries a plurality of frames 7 of any usual or conventional construction. Above these frames and resting upon the upper edges of walls 2 is the escape board 8 having an opening therein that the bees may pass from the super body to the hive, the super body being constructed as a rectangular member having walls 9 within which are located a plurality of honey frames or cartons 10. This super body rests upon the escape board 8 when such board is used though it is of course understood that the escape board is used only when honey is to be obtained from the super body and surrounding it may be positioned a rectangular rim comprised of sides 11 in the underside of which is formed one part of a lap joint 12 to connect with the complementary joint 13 formed on the upper edges of the outer walls 3 of the outside member of the hive body. Of course the super body and the rim is not an absolute essential of a hive though it is ordinarily used and is illustrated in the present construction. The cover for the hive may consist of a flat rectangular member 14 from which depend sides 15, their under edges being provided with joint members 16 to engage with a companion joint member 17 formed at the upper edges of the sides 11 of the rim.

The dead air space 4 between the walls 2 and 3 during the working season is closed at its upper end by bars 18 from one end of which project sheet metal vanes 19 which lie partially over the upper edges of the sides 3 of the outer member of the hive body. Four of these members are used, one at each side and end to completely cover the dead air space. In practice I prefer to form these members with an upwardly projecting edge 20 which comes directly in line with the upper edges of sides 2. During the

UNITED STATES PATENT OFFICE.

ALBERT G. WOODMAN, OF GRAND RAPIDS, MICHIGAN.

BEEHIVE.

1,242,628.

Specification of Letters Patent.

Patented Oct. 9, 1917.

Application filed January 26, 1916. Serial No. 74,391.

To all whom it may concern:

Be it known that I, ALBERT G. WOODMAN, a citizen of the United States of America, residing at Grand Rapids, in the county of Kent and State of Michigan, have invented certain new and useful Improvements in Beehives; and I do hereby declare the following to be a full, clear, and exact description of the invention, such as will enable others skilled in the art to which it appertains to make and use the same.

This invention relates to a hive for bees and it is the object and purpose, primarily, of the invention, to provide a hive construction by means of which bees in the hive may be protected against severe weather especially such as occurs in winter time. The invention comprises various constructions and arrangements of parts such that this protection may be readily afforded and at the same time no complicated or involved construction be needed. For an understanding of the construction of the hive by means of which this end is attained, reference may be had to the accompanying drawing, in which:

Figure 1 is a perspective view with parts broken away and shown in section of the hive body illustrating the means used to protect the swarm in winter weather.

Fig. 2 is a perspective view of the hive body, the frames being removed therefrom and showing the removable strips used during the working season or during warmer weather.

Fig. 3 is a transverse section taken through the parts of a complete hive, these parts being separated and located one above the other for a clearer showing of the construction.

Fig. 4 is a perspective view of one of the strips used to cover the dead air space between the separated parts of the hive body;

Fig. 5 is a perspective view of a corrugated paper box of conventional structure one or more of these boxes being used to help house the swarm in the hive body during winter weather, one box telescoping into another when more than one is used; and

Fig. 6 is a perspective view of an entrance member to the hive.

Like reference characters refer to like parts throughout the several views of the drawing.

In the construction of the hive a base 1 is provided, this being separable from the

hive body and reversible, the hive body being positioned above this base and consisting of inner and outer open ended rectangular parts having sides 2 and 3, sides 2 of the inner part being located within the sides 3 of the outer part and spaced a distance therefrom to make a dead air space 4 between all of the sides or walls 2 and 3. Adjacent the lower edges the sides 2 and 3 are connected by bars as 5 shown in Fig. 3 so that the inner and outer members are inseparably connected together. These bars 5 are located above and rest upon lower bars 6 on the base. The inner part of the hive body carries a plurality of frames 7 of any usual or conventional construction. Above these frames and resting upon the upper edges of walls 2 is the escape board 8 having an opening therein that the bees may pass from the super body to the hive, the super body being constructed as a rectangular member having walls 9 within which are located a plurality of honey frames or cartons 10. This super body rests upon the escape board 8 when such board is used though it is of course understood that the escape board is used only when honey is to be obtained from the super body and surrounding it may be positioned a rectangular rim comprised of sides 11 in the underside of which is formed one part of a lap joint 12 to connect with the complementary joint 13 formed on the upper edges of the outer walls 3 of the outside member of the hive body. Of course the super body and the rim is not an absolute essential of a hive though it is ordinarily used and is illustrated in the present construction. The cover for the hive may consist of a flat rectangular member 14 from which depend sides 15, their under edges being provided with joint members 16 to engage with a companion joint member 17 formed at the upper edges of the sides 11 of the rim.

The dead air space 4 between the walls 2 and 3 during the working season is closed at its upper end by bars 18 from one end of which project sheet metal vanes 19 which lie partially over the upper edges of the sides 3 of the outer member of the hive body. Four of these members are used, one at each side and end to completely cover the dead air space. In practice I prefer to form these members with an upwardly projecting edge 20 which comes directly in line with the upper edges of sides 2. During the