

July 8, 1930.

A. G. WOODMAN

1,770,259

BINDING STRIP

Filed April 29, 1929

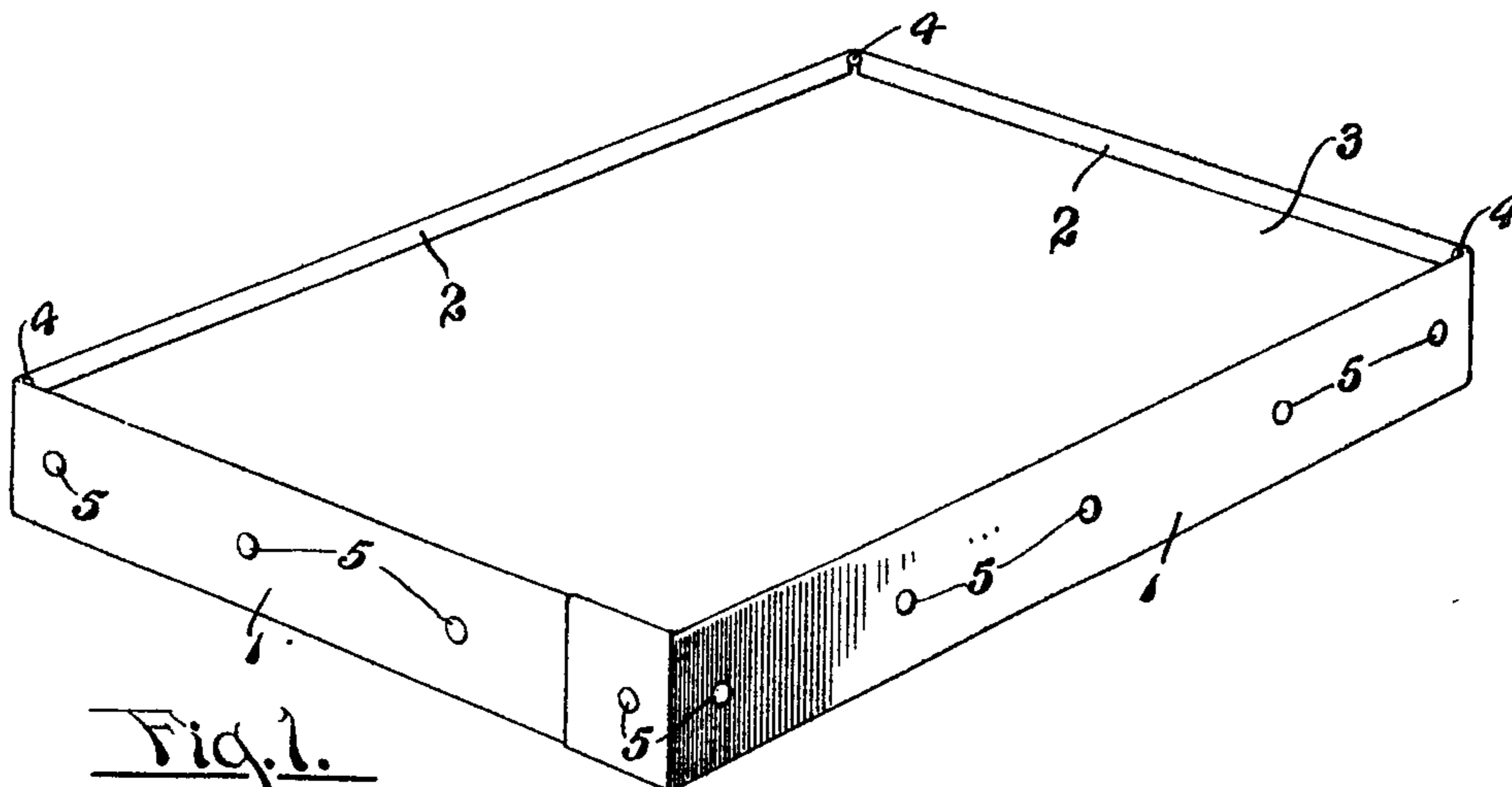

Fig. 1.

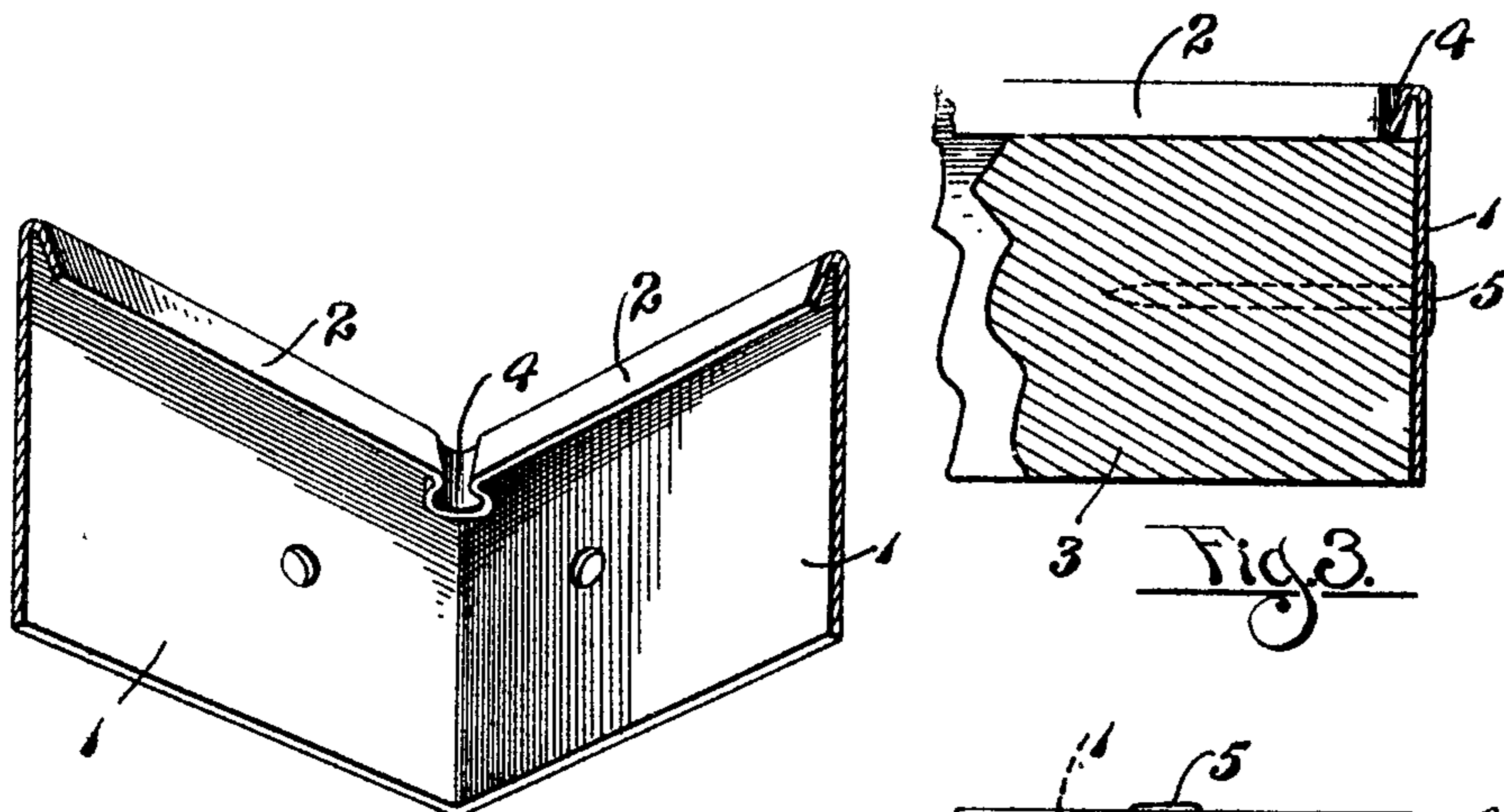

Fig. 2.

Fig. 3.

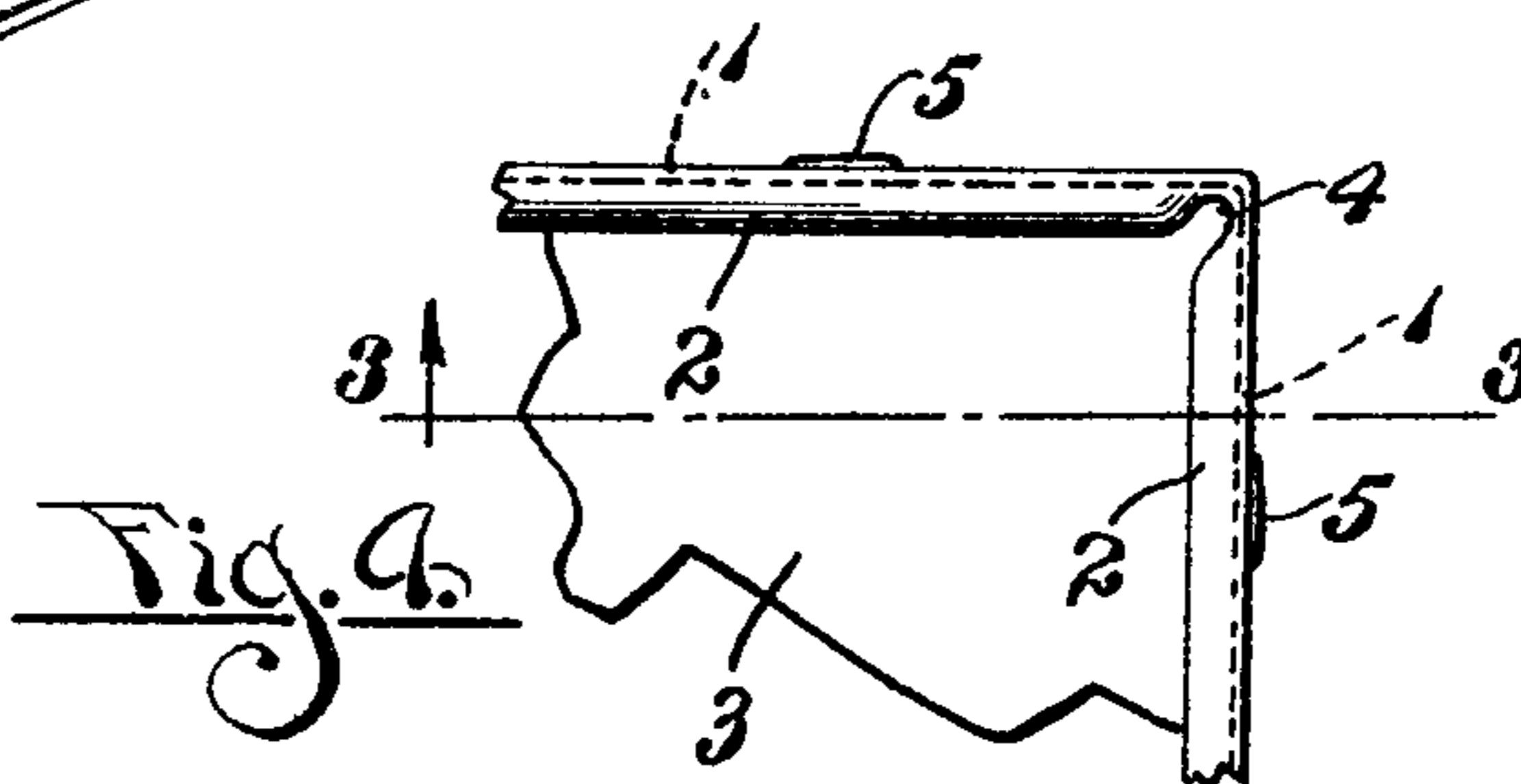

Fig. 4.

Inventor
Albert G. Woodman
By - Liverance and
Van Antwerp
Attorneys

UNITED STATES PATENT OFFICE

ALBERT G. WOODMAN, OF GRAND RAPIDS, MICHIGAN

BINDING STRIP

Application filed April 29, 1929. Serial No. 358,851.

This invention relates to a binding strip of metal which, in use, is adapted to be placed around a base member having corners, the binding strip being bent at the corner to fit the base. There are many relations in which this binding strip may be used and in practice I have used the same to bind and connect the fabric member of a bee smoker bellows to opposed bases though it is to be understood that the binding strip is adapted for use in many other places.

Binding strips of this character are ordinarily formed with an inturned flange at one edge and my invention is primarily concerned with a novel construction whereby the strip with the integral flange may be readily bent at the places necessary to conform the strip around the corners of the member to which it is to be secured. And I have attained this result in a relatively simple but very practical and satisfactory manner as will be apparent from the following description of the invention taken in connection with the accompanying drawing, in which,

Fig. 1 is a perspective view showing the binding strip located around and secured to a base member.

Fig. 2 is a fragmentary enlarged perspective view illustrating one corner portion of the strip.

Fig. 3 is a fragmentary enlarged section substantially on the plane of line 3-3 in Fig. 4.

Fig. 4 is a fragmentary plan view of the construction shown in Fig. 3.

Like reference characters refer to like parts in the different figures of the drawing.

The binding strip 1 of flat metal is of a length to pass entirely around the base member to which it is to be secured. The strip at one edge is formed with an inwardly turned flange 2 located at an angle to the plane of the body of the strip and when the strip is placed around and attached to a base member, as 3, the edges of the flanges 2 bear against a side of said member.

The strip at the places where it is to turn the corners around the base member is pressed inwardly at the flange portions thereof forming rounded beads 4 which are shaped so that

the sides are parallel to the section of the binding strip 1 at each side of a corner, thereby permitting the strip to be readily bent at said corner without buckling of the metal or distortion thereof in any respect. The binding strip is formed with as many of the beads 4 in the flanges 2 as there are corners to be turned about the base member and the beads 4 are positioned proper distances apart so that the same come exactly at the corners of the base member.

The strip is provided with a plurality of openings in its length through which nails 5 or similar fastening devices may be driven into the base member when the strip is applied thereto. The ends of the strip overlap and there is but one joint in the strip around the entire base.

With this construction of binding strip the beads 4 curled or dented in at the corners permits the binding strip to pass around the corners without cutting away any portion of the flanges 2 as has been the usual practice at the corners heretofore with binding strips of this character. Cutting away portions of the flanges where the strip is bent around the corners of the base leaves edges, sometimes rough and sharp, which are disadvantageous in a device of this character, while the strip with the integral curved beads in the flanges at the corners thereof are smooth and unbroken and do not present any rough or sharp edges. The flanges 2 form a surrounding bead which presents a smooth and rounded outer edge to the strip, and with the binding strip as made in accordance with this invention all portions of the strip which may be contacted against are smooth without roughened or sharp edges at any portion. Moreover, the corners made are of considerably greater strength and rigidity than when parts of the flanges 2 are cut away to permit ready bending.

The construction while of relatively simple character is one of merit and has proved its worth in actual practice. The invention is defined in the appended claims and is to be considered comprehensive of all forms of structure coming within the scope of the claims.

I claim:

1. In a construction of the class described, a base member having corners, a binding strip of flat metal located around said base member
5 comprising a continuous length of flat metal formed at one longitudinal edge with a return bent flange located at an angle to the body of said strip, the edge of said flange bearing against a side of the base member, and
10 said flange at the corners of said base member being pressed toward the body of the binding strip into beads continuous with the flange.

2. In a construction of the class described, a rectangular base member, a binding strip
15 surrounding said base member comprising a continuous length of flat metal having a flange at a longitudinal edge thereof bent back toward the base member at an angle to the body of the binding strip, and beads in
20 said flange pressed toward the body of the binding strip at the corners of the base member.

3. In a construction of the class described, a base member, a binding strip of flat metal
25 around said base member formed with a flange at one longitudinal edge bent back toward and engaging against the base member, said flange at the corners of the base member being continuous and formed into shape to
30 permit the ready turning of the corners of said base member by the binding strip.

In testimony whereof I affix my signature.
ALBERT G. WOODMAN.

35

40

45

50

55

60