

Oct. 18, 1932.

H. H. ROOT
COMB FOUNDATION
Filed Aug. 13, 1927

1,882,938

Fig. 1.

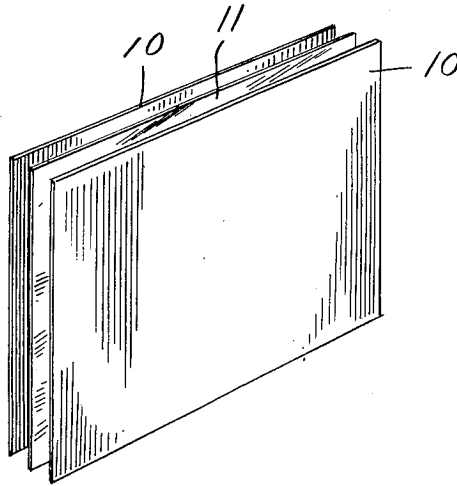
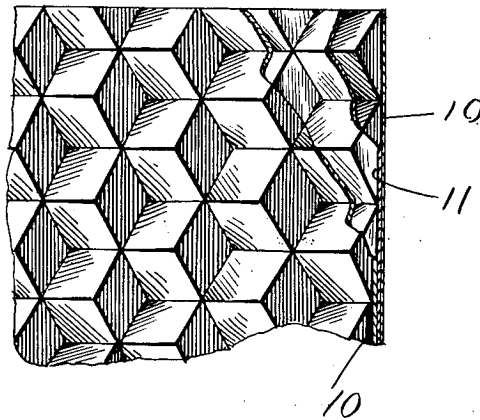

Fig. 2.



Inventor
Huber H. Root
By *Chas. Williamson*
Attorney

UNITED STATES PATENT OFFICE

HUBER H. ROOT, OF MEDINA, OHIO, ASSIGNOR TO THE A. I. ROOT COMPANY, OF MEDINA, OHIO, A CORPORATION OF OHIO

COMB FOUNDATION

Application filed August-13, 1927. Serial No. 212,735.

My invention relates to comb foundation for use in beehives. Such foundation ordinarily consists of a sheet of beeswax which by the use of dies, or an embossing operation, is formed on opposite sides with beginnings in greater or less degree of the cells. Honey comb made by the bees from such ordinary foundation will sag in the hive, with the result that the cells of the upper part will be distorted and comb cells in which the queen should lay worker eggs will not be used at all for brood or the queen will lay undesirable drone eggs therein. The worker brood area or capacity of the comb is thus restricted and may result in serious reduction in the strength of the colony. The solution of the problem which this tendency of ordinary beeswax foundation has to stretch and sag and result in deformation of the cells has been sought by others in various ways all of which known to me have been objectionable for one reason or another. Thus wires have been embedded in the foundation extending in various directions, these being objectionable because they are expensive and when intersecting wires are employed the bees often construct irregular cells at the point of intersection of the wires. Wood and other materials have been proposed but because of mechanical difficulties, and of objection thereto by the bees for one reason or another their use has not been an acceptable or satisfactory solution of the problem. The elements or factors entering into the problem are thus economy of manufacture, avoidance of mechanical difficulties either in manufacture or occurring in the use of the foundation in the hive, and acceptability by the bees. A highly satisfactory solution of the problem presented was found by me in the subject of United States Patent No. 1,583,605, May 4, 1926, in the use of superimposed sheets or layers, two outer ones of beeswax and an inner one of blended vegetable wax and beeswax. By my present invention I avoid the use of a middle layer or ply of a blend of vegetable wax and beeswax,—in fact using no wax at all in a middle ply and employ in place thereof a material which like the blend of vegetable wax and beeswax fulfills all the practical requirements as to

manufacture and acceptability to the bees, and which will serve the purpose of preventing sagging or distortion of the foundation, such as takes place with foundation of beeswax.

My invention consists in whatever is described by or is included within the terms or scope of the appended claims.

In the annexed drawing:

Fig. 1 is a perspective view of portions of the inner and outer sheets of material which in what I now consider the best embodiment of my invention are used in production of comb foundation, the sheets being shown separated and before being fastened;

Fig. 2 is a perspective view of a portion of comb foundation when made of the sheets of material shown in Fig. 1 with portions of one of the outer and of the inner layers or lamina broken away.

The foundation shown in the drawing to exemplify my invention is a laminated structure of three layers or sheets, the two outer layers, 10, being of pure beeswax and the inner layer, 11, being a manufactured product which on the market is known as "cellophane," and which may be readily obtained under that name. This material as I use it is a sheet that is very thin, about the thinness of letter paper approximately about one to three one-thousandths of an inch and which may be considered a paper-like material, in that it is flexible and capable of being formed with depressions corresponding to the hexagonal cell bases, but unlike true paper is non-fibrous, so that it has a smooth surface on which no fibrous formation is presented, the absence of fibers being of great importance because bees will gnaw fibrous material sooner or later. Such material also has the important property that unlike celluloid, bakelite, and other synthetic materials, it has no odor which is objectionable to bees, and hence, the foundation made in accordance with my present invention is not open to objection by the bees on the score of odor, but is entirely acceptable to them. Another important physical characteristic of cellophane is its transparency so that there is nothing objectionable in the appearance of the founda-

55

60

65

70

75

80

85

90

95

100

tion in which it enters. Said material also has the requisite characteristics of toughness and strength for imparting to the foundation its lack in such respects when made as ordinary foundation is of pure beeswax, and thus foundation made in accordance with my invention has the non-stretching characteristic which is so important.

The layers or plies which form the sheet of foundation are joined in a unitary or composite sheet by the natural adhesiveness or stickiness of wax, and by the interlocking of the adjacent surfaces by the favose condition. However, it is not necessary in the practice of my invention to provide the outer plies in the form of already-made sheets of pure beeswax, but the sheet of cellophane or paper-like material having properties above set forth may be run through a bath of melted pure beeswax and thereby is caused the application of a coating or exterior covering of pure beeswax on opposite sides thereof, and then the resulting product is run through a foundation mill.

By reason of the fact that cellophane may be used, in a very thin sheet and yet have the necessary or desired strength, the layers of beeswax may be made relatively thinner, this having the very important advantage of reduction of weight of the sheet of foundation, and thus giving a greater number of sheets of foundation to the pound. Foundation made in accordance with my present invention will not break in shipping nor in the honey extractor. If by accident the combs are mutilated they may be melted up over a fire and the thin middle ply will not melt nor mix with the beeswax. Its resistance to heat enables the foundations to withstand melting by the hottest sun. The name "cellophane" is a trade name for a material which chemically is regenerated cellulose.

What I claim is:

1. Comb foundation comprising layers of beeswax and regenerated cellulose in the form of a thin sheet.

2. Comb foundation comprising layers of beeswax and regenerated cellulose in the form of a thin sheet between the beeswax layers.

In testimony whereof I hereunto affix my signature.

HUBER H. ROOT.

55

60

65