

Oct. 25, 1932.

D. E. LHOMMEDIU

1,885,030

AUTOMATIC BEE COMB FILLER

Filed Jan. 2, 1932

2 Sheets-Sheet 1

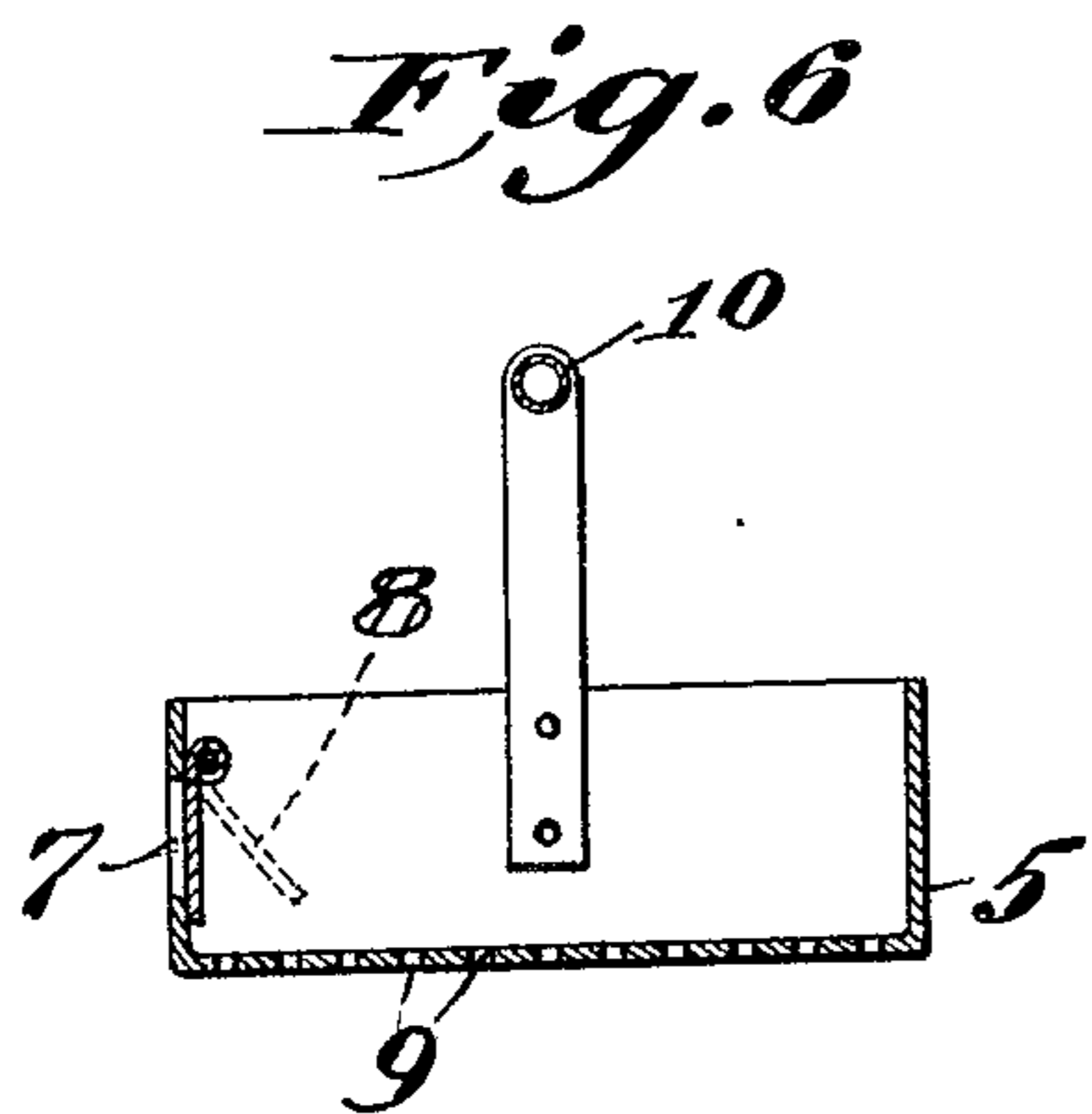
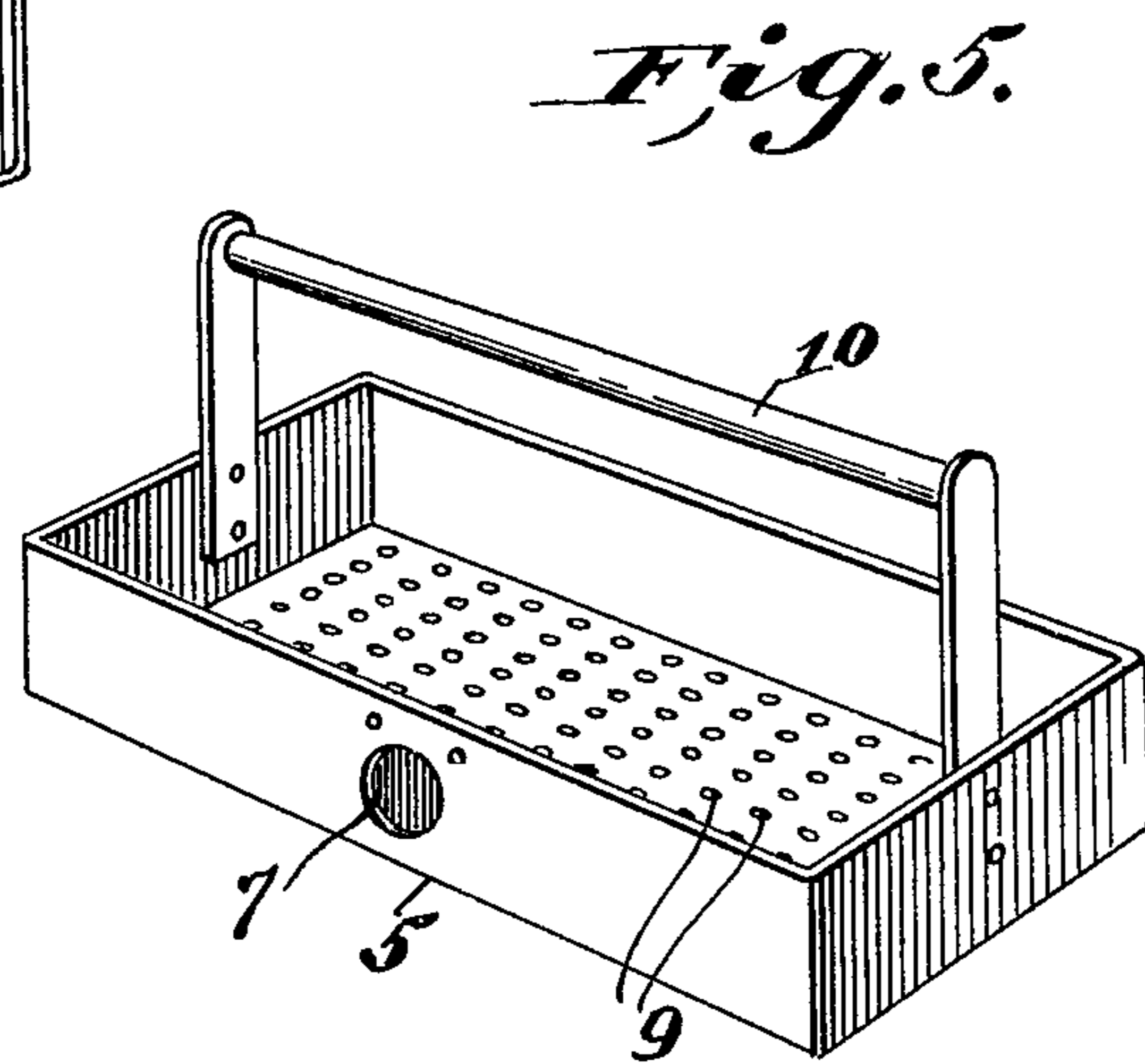
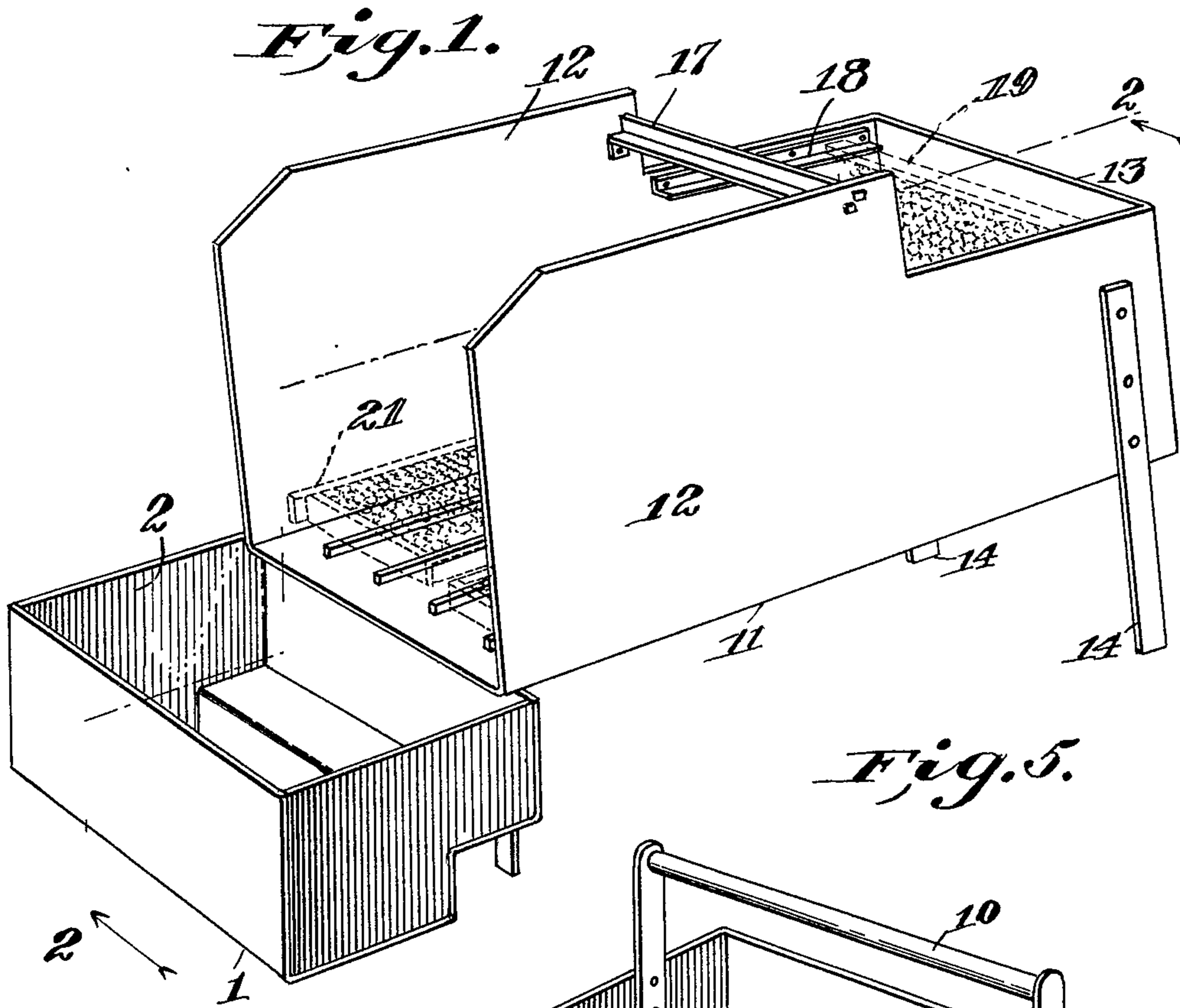

INVENTOR.  
*Delbert E. Lhommedieu.*  
BY  
*E. C. Bloomer & Co.,*  
ATTORNEYS.



# UNITED STATES PATENT OFFICE

DELBERT E. LHOMMEDIEU, OF COLO, IOWA

AUTOMATIC BEE-COMB FILLER

Application filed January 2, 1932. Serial No. 584,488.

This invention relates to an automatic bee-comb filler.

An object of the invention is the construction of a simple and efficient apparatus for filling bee-combs for use in feeding or stimulating the bees to increase the productive capacity of each colony.

Another object of the invention is the construction of an apparatus which will hold the frames containing the combs to be filled with syrup in a horizontal position during the filling process, and then permit the frames to be hung in a vertical position for allowing the surplus syrup to be drained from the combs.

A still further object of the invention is the construction of a simple and efficient filling and draining pan or casing, mounted upon a syrup tank, whereby the combs in frames, for feeding bees, can be easily filled with the syrup, then suspended for draining surplus syrup from said combs, and allowing the surplus syrup to run back into the syrup tank.

With the foregoing and other objects in view, my invention comprises certain novel constructions, combinations and arrangements of parts as will be hereinafter fully described, illustrated in the accompanying drawings, and more particularly pointed out in the appended claims.

In the drawings:

Figure 1 is a perspective view of an apparatus constructed in accordance with the present invention, while

Figure 2 is a longitudinal, sectional view of the same, taken on line 2—2, Fig. 1, and looking in the direction of the arrows.

Figure 3 is a sectional view taken on line 3—3, Figure 2, and looking in the direction of the arrows.

Figure 4 is a sectional view taken on line 4—4, Fig. 2, and looking in the direction of the arrows.

Figure 5 is a perspective view of the syrup dipper or sprinkler, while

Figure 6 is a transverse view of the same.

Referring to the drawings by numerals, 1 designates a syrup tank, which comprises an upper portion 2 and a bottom 3, in which is

formed a depending pocket-like portion 4; in this pocket 4 is seated a syrup dipper or sprinkler 5. The inner portion of the syrup tank 2 is supported by preferably two legs 6 (Fig. 4).

The sprinkler 5 comprises a body in one side of which is formed an aperture 7 that is normally closed by a flap valve 8. The bottom of the sprinkler has a great many apertures 9 therein, so as to allow the syrup to pass readily from the sprinkler on to the combs, as hereinafter described. The valved side of the sprinkler allows it to more quickly fill when placed in the pocket 4 of the syrup tank, as shown in Figure 2. A suitable handle 10 is attached to the sprinkler.

A filling and draining pan or casing 11 is provided, comprising sides 12, an outer end 13 and an open inner end. The outer end of the casing 11 is supported by legs 14. Attached to the bottom 15 of the casing 11 are a pair of parallel angle irons 16, Fig. 2. These irons 16 are spaced apart, whereby the upper edge of the syrup tank 1 can be placed therebetween; this positioning of the casing 11 upon tank 1 holds these two units in an efficient assembled position. The legs 14 are of sufficient height to cause the bottom 15 of casing 11 to slant towards the syrup tank, so that surplus syrup on the floor 15 will readily discharge into the syrup tank 1. The sides 12 are braced by an angle brace 17, the ends of which are bent at right angles and securely fastened to the inner faces of the sides 12, Figs. 1 and 2. Secured to the inner face of each side 12 and near end 13 is an angle bracket 18. These two brackets 18 afford means for supporting frames 19 (dotted lines), to allow draining of surplus syrup therefrom, after the cells of the comb have been filled. A number of longitudinal parallel supporting strips or ribs 20 are formed upon the bottom 15 of the casing 11, near its discharge end, and on these ribs 20 are placed the empty frames 21 (dotted lines), the empty combs or cells of which are to be filled with the syrup from tank 1. These ribs 20 prevent the horizontal frames 21 from lying snugly against the bottom 15, whereby

surplus syrup can run under the frames and thence discharge into the tank 1.

The sprinkler is lifted by the operator from the position shown in dotted lines in Figure 2, and then moved to between the sides 12 over the horizontal frames 21, allowing the syrup to be discharged onto the empty combs or cells, filling the same. Then the combs are moved to the vertical position and hung or suspended from brackets 18, as shown by the dotted frame 19, whereby the surplus syrup is drained from the frame, prior to placing the filled frame in the hive.

From the foregoing description, it will be understood that I have provided simple and efficient means for placing the frames containing the empty combs or cells in position for filling the same from the syrup tank. The filled frames are hung in the apparatus for draining, prior to placing them in the brood compartment of the hive, whereby the bees can easily feed upon the syrup, resulting in not only supplying the bees with the necessary food, but also greatly stimulating the same, whereby the colony is built up at the time the operator desires, so that there will be a strong and vigorous colony ready to take care of the greatest honey flow, resulting in greater profit to the apiarist. Further, the apparatus can be quickly mounted or assembled as shown in Fig. 1, or quickly disassembled, with the syrup tank stored in the casing 11, if the apiarist so desires.

While I have described the preferred embodiment of my invention and illustrated the same in the accompanying drawings, certain minor changes or alterations may appear to one skilled in the art to which this invention relates, during the extensive manufacture of the same, and I, therefore, reserve the right to make such changes or alterations as shall fairly fall within the scope of the appended claims.

What I claim is:

1. In an apparatus of the class described, the combination of a casing provided with frame supporting means on its bottom, and said casing provided with frame suspending means on its side.
2. In an apparatus of the class described, the combination of a casing provided with means for supporting horizontally positioned frames to be filled, and said casing provided with means for suspending filled frames.
3. In an apparatus of the class described, the combination of a casing provided with sides and a bottom, said bottom provided near the discharge end of said casing with longitudinally extending spaced strips or ribs, said sides provided to one side of said ribs and near the top of said casing with substantially horizontal frame supporting brackets, and a brace extending across said casing and connected at its ends to said sides above said ribs and brackets.

4. In an apparatus of the class described, the combination of a casing provided with sides, and an angle brace having its ends bent at right angles and secured to said sides.

5. In an apparatus of the class described, the combination of a casing, and said casing provided with frame-supporting ribs and brackets.

6. In an apparatus of the class described, the combination of a casing, and said casing provided on its bottom with frame-supporting means and on its side with frame-suspending means.

7. In an apparatus of the class described, the combination of a casing, and said casing provided on its bottom with longitudinally extending strips or ribs and on its sides with longitudinally extending brackets.

8. In an apparatus of the class described, the combination of a casing provided with a closed outer end and an open inner discharge end, frame-supporting brackets contiguous to said closed outer end, and frame-supporting ribs contiguous to said discharge end.

9. In an apparatus of the class described, the combination of a normally inclined casing provided with an open top and an open discharge end, means in said casing for supporting a frame to be filled, and means in said casing to one side of said supporting means for suspending a filled frame for drainage.

10. In an apparatus of the class described, the combination of a casing, and parallel irons fastened to said casing, whereby a syrup tank may be positioned between said parallel irons against accidental displacement.

11. In an apparatus of the class described, the combination of a casing, and means on its bottom for receiving a portion of a syrup tank.

12. In an apparatus of the class described, the combination of a casing, and parallel transversely positioned spaced irons fastened to the bottom of said casing near its discharge end.

In testimony whereof I hereunto affix my signature.

DELBERT E. LHOMMEDIU.

115

120

125

130