

Dec. 31, 1946.

R. H. VOLGENAU ET AL

2,413,394

TOOL FOR REMOVING WAX FROM BEEHIVE FRAMES

Filed July 2, 1945

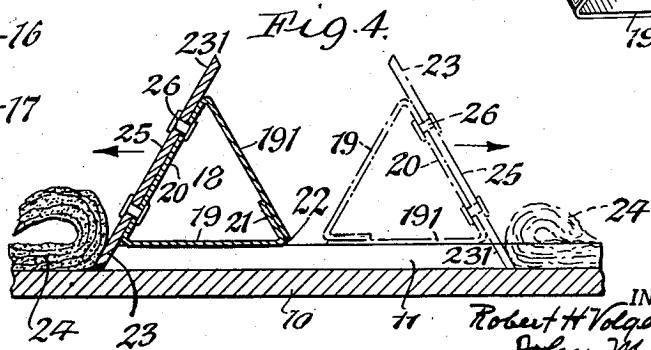
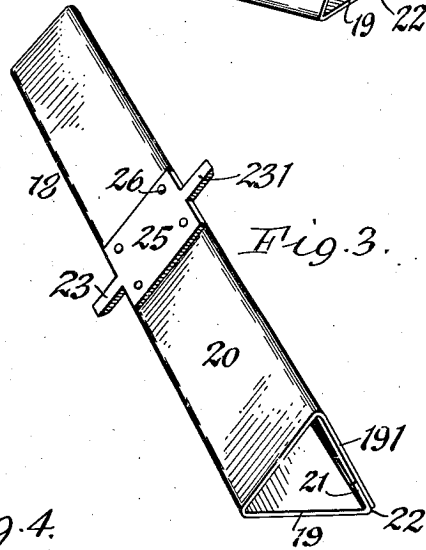
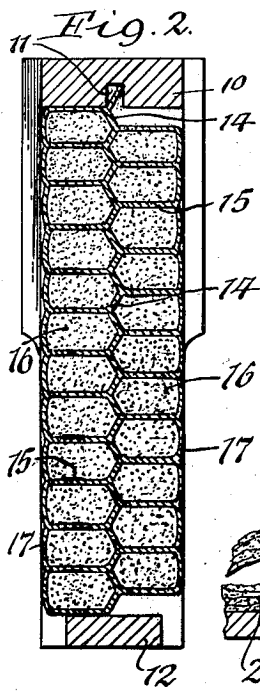
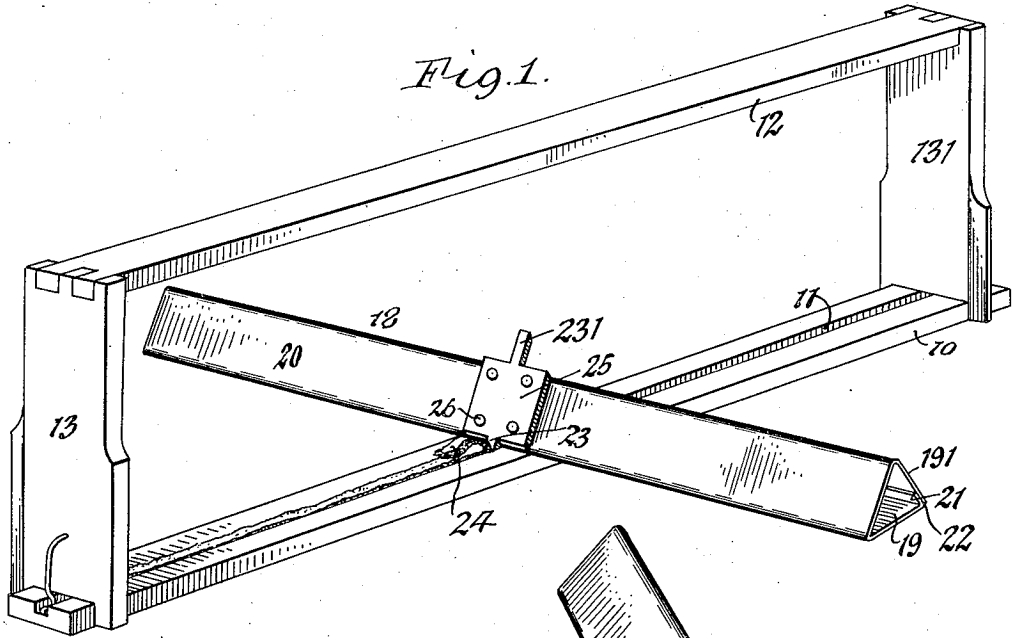

INVENTORS:
Robert H. Volgenau
BY John W. Hoar

John W. Hoar

ATTORNEYS.

UNITED STATES PATENT OFFICE

2,413,394

TOOL FOR REMOVING WAX FROM BEEHIVE FRAMES

Robert H. Volgenau, Buffalo, and John M. Hooe,
Ogdensburg, N. Y.

Application July 2, 1945, Serial No. 602,888

4 Claims. (Cl. 30-169)

1

This invention relates to a tool for removing wax from the frames of beehives and more particularly for cleaning out the wax from the grooves in beehive frames which are adapted to receive one edge of a wax foundation sheet or film usually employed to facilitate the work of the bees in the formation of the cells which are subsequently filled with honey.

It is therefore the object of this invention to provide a tool of simple construction for efficiently removing the wax from the grooves in beehive frames and which permits this operation to be performed very quickly and easily and with a minimum amount of effort.

In the accompanying drawing:

Fig. 1 is a perspective view showing a tool embodying this invention in position for use on a beehive frame for removing the wax from a groove therein.

Fig. 2 is a vertical cross section of a beehive frame showing a usual complete comb filled with honey mounted therein.

Fig. 3 is a perspective view of the wax removing or cleaning tool separate from the beehive frame.

Fig. 4 is a fragmentary longitudinal section of the grooved member of a beehive frame and the wax removal tool shown in a position on this frame member for removing the wax from its groove.

One form of beehive frame now in general use comprises an upper horizontal bar 10 which is provided on its underside with a longitudinal groove 11, a lower horizontal bar 12 which is spaced from the upper bar and two vertical end bars 13, 13' which respectively connect the corresponding ends of said longitudinal bars.

In using a frame of this character the bee keeper places a sheet-like foundation or film 14 of wax in an upright position within this frame with its lower edge resting on the lower bar 12 and its upper edge projecting into the groove 11 of the upper bar so as to hold this foundation or film in an upright position. This frame together with the foundation sheet mounted therein is then placed within the beehive and thereafter the bees build a plurality of cells 15 on opposite sides of the foundation sheet so that the latter forms the inner or rear heads of the several cells and after these cells have been completed the bees fill them with honey 16 and then seal the outer or front ends of the cells by means of wax caps 17.

The tool embodying the present invention for removal of the wax from the groove 11 of the

2

beehive frame, after the cells have been removed therefrom, is preferably constructed as follows:

The numeral 18 represents a handle bar which is adapted to be placed across the inner face of the grooved bar of the beehive frame and moved lengthwise thereof by grasping opposite ends of this bar with both hands and moving this bar back and forth along the inner side of this frame bar. The engagement of this handle bar with the grooved frame bar and the reciprocation of the handle bar lengthwise of this frame bar is preferably effected while the beehive frame is in an inverted position so that the upper frame bar 10 is lowermost and has its groove 11 facing upwardly, as shown in Figs. 1 and 4, inasmuch as this manner of using the tool on the beehive frame is more convenient and enables the tool to be used more effectively.

Although the handle bar may be constructed of different materials and in various forms, the same is preferably made of sheet metal which is bent into the form of a tube which is triangular in cross section and provides three equilateral walls 19, 19', 20. As shown in Figs. 1, 3 and 4, the adjacent longitudinal edges of the sheet of metal from which this tubular handle bar is constructed are connected with each other by means of a flange 21 arranged along one of the longitudinal edges of the wall 19 of the handle bar and connected by means of spot welding, brazing or the like with the inner side of the adjacent wall of the handle bar but any other suitable means may be employed for connecting these parts of the handle bar.

The two adjacent walls 19, 19' of the handle bar form guide faces, either of which may be utilized as a guide whereby this handle bar may slide with its central part back and forth on the inner side of the inverted or grooved upper bar 10 of the beehive frame, while the latter is in an inverted position, one of these guides being used while moving the handle bar lengthwise of the grooved frame bar in one direction while the other guide of the handle bar engages the inner side of the grooved frame bar while sliding the handle bar thereon in the opposite direction. Such reversal in the position of the handle bar on the respective frame bar is effected by turning the handle bar alternately in opposite directions while the handle bar engages the apex or corner 22 between its guide walls 19, 19', as a fulcrum, on the inner side of the grooved frame bar when the handle bar reaches the end of a stroke in either direction.

The third face or wall 20 of the handle bar

3

forms a bearing or support upon which are mounted cutting bits or blades 23, 23' which are adapted to project alternately into the groove 11 of the frame bar 16 and to remove the wax 24 therefrom by reciprocating the handle bar relative to the grooved frame bar and alternately moving the cutter blades into and out of their operative position relative to the wax in this groove.

These two cutter blades or bits project laterally from the central part of the handle bar and are arranged in the same plane so that when the handle bar rests with one of its guide walls on the grooved member of the beehive frame, one of these cutter blades will project downwardly into the groove 11 of the beehive frame, and at a forwardly inclined angle relative thereto, so that upon moving the handle bar forwardly with the operative cutter blade advancing toward one end of this groove, this blade will operate as a plow and not only dig into the wax in the groove but also lift it upwardly therefrom into a position where it can be brushed aside by the operator, as shown by full lines at the left of Fig. 4.

When the operator has moved the handle bar to the end of its stroke in one direction the blade which has just been in use is lifted out of the groove in the beehive frame and the other cutter blade is moved downwardly into this groove by merely turning the handle bar about its longitudinal axis in the reversed direction during which movement the apex or corner 22 between the two guide walls turns on the inner side of the grooved frame bar as a fulcrum and thus lifts the guide wall which has just been in use out of engagement from the inner side of the grooved frame bar and lowers the other guide wall into engagement with the inner side of this grooved bar. It therefore follows that the other cutter blade or bit is projected downwardly into this groove at an angle but in a reverse position. Upon now moving the handle bar bodily in the opposite direction its operative cutter blade will dig into the wax in the groove 11 and lift the same therefrom during the stroke of the handle bar in the respective direction, as shown by dotted lines at the right of Fig. 4.

Upon reciprocating the handle bar in this manner a number of times and also rotating the handle bar upon its longitudinal axis so as to alternately project its cutter blades into the groove 11 the wax in the latter will be wholly removed therefrom and leave the same free from obstruction, thus permitting of introducing the longitudinal edge of a new wax foundation sheet into this groove in assembling the parts preparatory to building the cells for a new honey comb.

In the preferred construction the two bits or cutter blades are formed integrally with a supporting plate 25 at opposite edges thereof, which plate may be secured to the bearing wall 20 of the handle bar by means of rivets 26 as shown in Figs. 1, 3 and 4 or by any other suitable means.

As a whole this tool for removing wax from the grooves of beehive frames is very simple in construction, the same can be easily operated and its use in the manner described permits of removing wax from the grooves of beehive frames very rapidly and efficiently, thereby effecting a considerable economy in the operation of servicing beehive frames.

We claim as our invention:

1. A tool for removing wax from a groove in a honey frame comprising a handle bar adapted to engage said frame across the groove thereof and

4

to be alternately moved in opposite directions thereon and turned about its axis so that the bar is arranged at one angle to the frame while moving in one direction and at a reverse angle when moving in the opposite direction, and cutter blades mounted on said bar and projecting transversely in opposite directions therefrom and one of said blades being adapted to enter said groove and remove the wax therefrom upon moving the bar in one direction and the other blade being adapted to engage said groove and remove the wax therefrom upon turning said bar about its axis and moving the same in the opposite direction.

2. A tool for removing wax from a groove in a honey frame comprising a handle bar adapted to engage said frame across the groove thereof and to be alternately moved in opposite directions thereon and turned about its axis so that the bar is arranged at one angle to the frame while moving in one direction and at a reverse angle when moving in the opposite direction, and cutter blades mounted on said bar and projecting transversely in opposite directions therefrom and one of said blades being adapted to enter said groove and remove the wax therefrom upon moving the bar in one direction and the other blade being adapted to engage said groove and remove the wax therefrom upon turning said bar about its axis and moving the same in the opposite direction, said bar being of triangular form in cross section and providing two adjacent guide faces arranged at an angle relative to each other which are adapted to slide alternately in opposite directions on said frame, and another face which is arranged at an angle relative to the guide faces and on which said blades are mounted and are adapted to be alternately presented at an angle to the groove in said frame.

3. A tool for removing wax from a groove in a honey frame comprising a handle bar adapted to engage said frame across the groove thereof and to be alternately moved in opposite directions thereon and turned about its axis so that the bar is arranged at one angle to the frame while moving in one direction and at a reverse angle when moving in the opposite direction, and cutter blades mounted on said bar and projecting transversely in opposite directions therefrom and one of said blades being adapted to enter said groove and remove the wax therefrom upon moving the bar in one direction and the other blade being adapted to engage said groove and remove the wax therefrom upon turning said bar about its axis and moving the same in the opposite direction, said bar being of triangular form in cross section and providing two adjacent guide faces arranged at an angle relative to each other which are adapted to slide alternately in opposite directions on said frame, and another face which is arranged at an angle relative to the guide faces and on which said blades are mounted and are adapted to be alternately presented at an angle to the groove in said frame, and said bar being constructed of a sheet metal which is bent into tubular form and has longitudinal edges which overlap one another.

4. A tool for removing wax from a groove in a honey frame comprising a handle bar adapted to engage said frame across the groove thereof and to be alternately moved in opposite directions thereon and turned about its axis so that the bar is arranged at one angle to the frame while moving in one direction and at a reverse angle when moving in the opposite direction, and cutter

5

blades mounted on said bar and projecting transversely in opposite directions therefrom and one of said blades being adapted to enter said groove and remove the wax therefrom upon moving the bar in one direction and the other blade being adapted to engage said groove and remove the wax therefrom upon turning said bar about its axis and moving the same in the opposite direction, said bar being of triangular form in cross section and providing two adjacent guide faces arranged at an angle relative to each other which

6

are adapted to slide alternately in opposite directions on said frame, and another face which is arranged at an angle relative to the guide faces and on which said blades are mounted and are adapted to be alternately presented at an angle to the groove in said frame and said blades being formed on opposite edges of a plate which is secured to the respective face of said bar.

ROBERT H. VOLGENAU.
JOHN M. HOOE.